

FINAL REPORT
EVALUATION OF THE LATE MERGE WORK ZONE
TRAFFIC CONTROL STRATEGY

Andrew G. Beacher
Graduate Research Assistant

Michael D. Fontaine, P.E.
Research Scientist

Nicholas J. Garber, Ph.D., P.E.
Faculty Research Scientist
and
Professor of Civil Engineering

Virginia Transportation Research Council
(A Cooperative Organization Sponsored Jointly by the
Virginia Department of Transportation and
the University of Virginia)

In Cooperation with the U.S. Department of Transportation
Federal Highway Administration

Charlottesville, Virginia

August 2004
VTRC 05-R6

DISCLAIMER

The contents of this report reflect the views of the authors, who are responsible for the facts and the accuracy of the data presented herein. The contents do not necessarily reflect the official views or policies of the Virginia Department of Transportation, the Commonwealth Transportation Board, or the Federal Highway Administration. This report does not constitute a standard, specification, or regulation.

Copyright 2004 by the Commonwealth of Virginia.

ABSTRACT

Several alternative lane merge strategies have been proposed in recent years to process vehicles through work zone lane closures more safely and efficiently. Among these is the late merge. With the late merge, drivers are instructed to use all lanes to the merge point and then take turns proceeding through the work zone. Its efficiency has been tested on only a limited basis. The purpose of this project was to determine when, if at all, deployment of the late merge was beneficial.

The late merge concept was evaluated by comparing it to the traditional merge using computer simulations and field evaluations. Computer simulations included analysis of 2-to-1, 3-to-1, and 3-to-2 lane closure configurations to determine its impact on throughput and the impact of factors such as free flow speed, demand volume, and percentage of heavy vehicles. Field tests were limited to 2-to-1 lane closures, as recommended by state transportation officials, and examined the impact of treatment type on vehicle throughput, percentage of vehicles in the closed lane, and time in queue.

Results of the computer simulations showed the late merge produced a statistically significant increase in throughput volume for only the 3-to-1-lane closure configuration and was beneficial across all factors for this type of closure. For the 2-to-1 and 3-to-2 lane closure configurations, the late merge increased throughput when the percentage of heavy vehicles was large.

Field tests showed similar trends with regard to throughput. Although throughput increased, the increase was not statistically significant because of the limited number of heavy vehicles at the site. More drivers were in the closed lane, indicating a response to the late merge signs. Time in queue was also reduced, although the reductions were not statistically significant.

The authors conclude that the late merge should be considered for 3-to-1 lane closure configurations but not until a sound methodology for deployment has been developed and tested in the field. For the 2-to-1 and 3-to-2 configurations, the late merge should be implemented only when the percentage of heavy vehicles is at least 20 percent.

FINAL REPORT

**EVALUATION OF THE LATE MERGE WORK ZONE
TRAFFIC CONTROL STRATEGY**

Andrew G. Beacher
Graduate Research Assistant

Michael D. Fontaine, P.E.
Research Scientist

Nicholas J. Garber, Ph.D., P.E.
Faculty Research Scientist
and
Professor of Civil Engineering

INTRODUCTION

Work zone lane closures in areas with high demand volumes are a source of frustration for transportation engineers and motorists alike. Not only can they lead to increased delays, travel times, and fuel consumption, but they are also associated with higher numbers of crashes and increased occurrences of aggressive driving. Transportation researchers have begun to look for innovative solutions to process traffic through highway work zones in a safer, more efficient manner. Alternative lane merge strategies have been designed to augment or replace the traditional merge concept specified in the *Manual on Uniform Traffic Control Devices (MUTCD)*¹ and the *Virginia Work Area Protection Manual (VAWAPM)*.² One such strategy is known as the late merge.

The concept behind the late merge is to make more efficient use of roadway storage space by allowing drivers to use all available traffic lanes to the merge point. Once the merge point is reached, the drivers in each lane take turns proceeding through the work zone. The combined effect of maximized storage and orderly merging operations may have the potential to increase throughput, reduce queue lengths, shorten travel times, and discourage aggressive driving. However, to date, the concept has been evaluated on only a limited basis in a small number of studies. It is still unclear whether the late merge, in practice, provides a worthwhile benefit and under what conditions it should be used.

Further, the late merge traffic control strategy requires a fundamental shift in driver merging behavior. For this reason, some transportation officials may be reluctant to implement the concept without clear demonstration of its merits. Given these facts, an examination of the concept was required for transportation professionals to consider the late merge a viable alternative to traditional traffic control.

PURPOSE AND SCOPE

The purpose of this project was to evaluate the late merge to determine its efficacy and proper deployment. Specific objectives were as follows:

- Investigate the late merge and the factors that influence its effectiveness using computer simulations and field tests on roads operated by the Virginia Department of Transportation (VDOT).
- Determine what benefits, if any, the late merge provides in terms of increased throughput, reduced travel times, reduced crashes, and road user cost savings.
- Based on knowledge gained from simulations and field tests, provide preliminary guidelines as to the conditions most appropriate, if any, for implementing the late merge.

The scope of the project included computer simulations of the traditional and late merge treatments in 2-to-1, 3-to-1, and 3-to-2 lane closure configurations and two before-and-after field tests of a 2-to-1 lane closure conducted over a period of several months. Although the literature review covered both the early and late merges, an investigation of each alternative was not considered possible within the time constraints of this project. Therefore, the scope of the project was limited to an analysis of the static late merge only.

METHODOLOGY

To evaluate the late merge, the methodology consisted of a literature review, development of traffic control plans, and detailed studies and analysis of traffic simulations and field experiments. In the simulations and field tests, the late merge was compared to the traditional MUTCD lane closure control as adopted in the VAWAPM. In addition, the simulation results were used to compare the road user costs for the two treatments.

Literature Review

The literature review covered different merging strategies in work zones, with a particular emphasis on the late merge and its deployment in the field. Of particular interest were the operating characteristics under which the late merge had been deployed, the plan used to implement the concept, and the results. Of these, the implementation plans were most important because they were necessary to create traffic control plans (TCPs) for the simulation and field experiments in this project.

The Virginia Transportation Research Council library, the University of Virginia Library, and the National Work Zone Safety Information Clearinghouse were used to identify literature relevant to this project.

Development of Traffic Control Plans

The development of TCPs was necessary to establish a framework for the simulation and field studies. Successful development required the incorporation of plans used in previous studies (from the literature review) and buy-in by VDOT officials who had a stake in the project.

Draft TCPs

Draft TCPs were developed using the computer aided drafting package Microstation. Each draft TCP included the traffic control as described in the studies examined during the literature review. Few changes were made to the original TCPs, except for correction of clerical errors.

Advisory Panel

After draft TCPs had been created, an advisory panel was established to gain the necessary buy-in from state transportation officials. The panel consisted of VDOT traffic engineers (including work zone safety coordinators from five districts and the statewide coordinator), personnel from VDOT's Mobility Management Division, and a representative of the Virginia State Police. This panel advised the researchers regarding the late merge traffic control to be deployed in the field and helped identify potential field test locations. The input from the advisory panel was used to modify the draft TCPs. The final TCPs were used to implement the late merge traffic control in the field.

Late Merge Simulation Development and Analysis

The purpose of the simulation was two-fold: first to determine traffic characteristics that could influence the performance of the merging alternatives, and second to compare the late merge and MUTCD treatments directly to determine whether throughput volumes improved for the late merge. The controlled environment offered in a simulation study was ideally suited for this type of study. To execute the study, the MUTCD TCP and the late merge TCPs selected by the advisory panel were used to create simulation models in VISSIM. VISSIM is a microscopic traffic model that offers the ability to control precisely how drivers make right-of-way decisions. This level of control was required to evaluate the turn-taking behavior required by the late merge.

Experimental Design

The simulation used a full factorial design to determine the effects of key parameters on vehicle throughput, and ultimately, how the late merge compared to the MUTCD treatment. The factors examined included traffic volumes in vehicles per hour per lane (vphpl), truck percentages, lane closure configuration, and desired free flow speeds. The combinations of variables evaluated through simulation are shown in Table 1. Each discrete combination of variables was simulated 30 times with different random number seeds to minimize the variability introduced by stochastic simulation.

Table 1. Variables Examined in Sensitivity Analysis

Factor	Number of Levels	Values of Factors
Approach Volume (vphpl)	4	500
		1,000
		1,500
		2,000
% Trucks	4	0
		10
		20
		30
Lane Closure Configuration	3	1 lane closed on 2-lane approach
		1 lane closed on 3-lane approach
		2 lanes closed on 3-lane approach
Desired Free flow Speed (mph)	2	60
		70

Calibration/Creation of Simulations

Creation of the simulation models required not only the establishment of the input files but also a calibration process using historic real-world data. Calibration involved accurately modeling driver merging behavior, placing simulated traffic control, and ensuring reasonable throughput values after the work zone.

Driver Merging Behavior

To model a standard work zone lane closure, the researchers needed to determine an approximate relationship between the percentage of traffic in the closed lane under free flowing conditions and the distance from the taper. Driver merging behavior for the MUTCD treatment was modeled based on data on the distributions of volumes by lane reported in previous studies.^{3,4,5,6,7} To determine distributions of volumes by lane approaching the work zone, the following factors were considered:

1. distance from taper
2. truck percentage
3. hourly volume per lane
4. number of open lanes
5. total number of lanes
6. side of lane closure (left or right)
7. posted speed limit.

These factors were examined using stepwise regression analysis to develop mathematical relationships that could predict lane distributions at any distance leading up to the lane closure.

Modelling merging behavior leading up to the taper was not necessary for the late merge since it was desired that drivers stay in their respective lane up to the taper. However, accurate modeling of turn-taking behavior was required once vehicles reached the taper. This was accomplished using VISSIM's priority rules. The priority rules were used to simulate turn-

taking behavior by setting them such that drivers were instructed to yield to the adjacent lane on an alternating basis. For this project, the default minimum gap times of 3 seconds and headways of 19 feet were used. In the event no vehicle was present in the adjacent lane, drivers were free to proceed through the work zone without delay. As a result, compliance with the late merge traffic control was close to 100 percent under congested conditions, which may or may not replicate what could be realistically seen in the field.

Simulation of Traffic Control

With the use of the merging behavior data, the requirements of the MUTCD¹ and VAWAPM² as to sign location and work zone configuration were incorporated into the model through the placement of links and decision arrows in VISSIM. Sign placement for the late merge had already been incorporated through priority rules. Decision arrows were necessary to simulate the response interaction between a driver and advance warning signs. The decision arrow prompted drivers to merge into the open lane(s) based on the values predicted by the regression model. After throughput values were observed to be consistent with the work zone capacity values in the *Highway Capacity Manual* (HCM),⁸ the simulations were considered calibrated.

Data Collection

Once calibrated, simulated lane closures for 3-to-2, 3-to-1, and 2-to-1 configurations were developed for each combination of factors shown in Table 1. Each simulated network was made up of a series of links stretching out just over 6 miles and represented a limited access highway. For each network, volume data were collected using data collection points. The data collection points were placed according to the lane configuration. For the 2-to-1 configuration, one data collection point was placed after the lane closure. For the 3-to-2 configuration, two points were placed, one for each lane. For the 3-to-1 configuration, two points were placed in the two-lane segment and one point was placed after the reduction to one lane. After completion of the input files for each combination of factors, data gathering commenced and simulations were run. As noted earlier, each discrete combination of variables was simulated 30 times with different random number seeds to minimize the variability introduced by stochastic simulation.

Data Reduction

For each simulation run, a text file was automatically generated by VISSIM showing the volume at each data collection point established within the corridor. From these files, the throughput volumes for each run were extracted and entered into a spreadsheet. The levels of the factors tested for each run were also recorded (demand volume, free flow speed, percentage of heavy vehicles present, and lane configuration).

Data Analysis

As discussed previously, factors were examined at various levels to determine if they played a significant role in the vehicle throughput for each treatment. Further, the two treatments were compared to determine whether the late merge significantly improved

throughput. Univariate and one-way analyses of variance (ANOVA) were selected to accomplish these tasks.

Univariate ANOVA

Since the simulations were in the form of a factorial experiment, a univariate ANOVA was used to assess the roles of these factors on throughput for both treatments. The Statistical Package for the Social Sciences program (SPSS) was used to perform all of the statistical analyses. For free flow speed, percentage of heavy vehicles, and volume, the actual values of the factor levels were used in the analysis. In addition to testing for significance among individual factors, interactions between factors were tested using the least significant difference (LSD) test. Finally, the results from the analyses for each treatment were compared to determine whether there was a significant difference in throughput between the two types of traffic control.

One-way ANOVA

The MUTCD and late merge were also compared by lane configuration separately to determine in each instance whether the late merge improved the efficiency of merging operations. In each instance, this was accomplished using one-way ANOVA.

Cost Savings

The computer program QUEWZ-92 was used to estimate road user costs for both traffic control scenarios. QUEWZ-92 determines user costs based on a combination of user delay costs and vehicle operating costs. The program simulates queuing and delay at a work zone lane closure and calculates the additional user costs as compared to the condition of no lane closure.⁹ The program assumes a value of time of \$17.89 per hour per person for passenger vehicles and a value of \$32.67 per hour for trucks (2003 dollars). The average car occupancy assumed by the program is 1.3 persons per vehicle.

The MUTCD and late merge were evaluated for the same three lane closure scenarios as were simulated: 2-to-1, 3-to-1, and 3-to-2 lanes closures. Each lane closure scenario was evaluated for four demand volume scenarios: 500, 1,000, 1,500, and 2,000 vphpl. Each scenario was then simulated with 1, 10, 20, and 30 percent heavy vehicles. The work zone capacity values were adjusted to the levels based on the results of the simulation output of throughput. These combinations of variables were tested in a hypothetical work zone where the traffic volumes were present 8 hours per day and the length of the work zone lane closure was 3 miles. The difference in user costs between the MUTCD traffic control and the late merge represents the cost savings achieved by using the late merge.

Field Tests

The field tests allowed for a real-world demonstration of the late merge. As with the simulations, the TCPs formed the experimental framework for the evaluation.

Five steps were used for the framework:

1. Procure traffic control.
2. Identify and select test sites.
3. Collect the data.
4. Reduce the data.
5. Analyze the data.

Traffic Control Procurement

The TCP for the field studies of the late merge called for traffic control consisting of orange advisory and white regulatory signs. VDOT sign shops manufactured the signs.

Identification and Selection of Test Sites

VDOT district traffic engineers and resident engineers were asked to identify sites that could be used for this study. To be selected for evaluation, candidate sites had to have the following characteristics:

1. a work zone that had been in place for at least 4 weeks
2. a closed single lane on a two-lane directional segment
3. congestion and queuing for some portion of the day
4. a work zone configuration from the start of the advance warning area to the taper that would remain essentially unchanged during testing
5. a work zone approach with a relatively straight alignment
6. ample room on the shoulders on the work zone approach to set up data collection equipment.

After candidate sites were identified, the project team went to the locations to rank them according to their varying suitability for the project. Sites were ranked based on whether congestion was recurring at the site and whether data could be collected safely.

Data Collection

Data were collected from July through September 2003. Data collection equipment was deployed at each site to collect traffic counts, queue lengths, and travel times. Data were collected only when there was congestion and queuing at the site. Measures of effectiveness (MOEs) chosen for the field experiments were:

1. distribution of traffic across the travel lanes approaching the work zone merge taper
2. throughput at the lane closure

3. travel time in queue.

Traffic Counts

Traffic counters and temporary inductive loop detectors were used to collect traffic data. Actual locations at each site varied based on the site characteristics, but generally the counter/detector stations were located just past the merge point (to get an idea of the total throughput of the various traffic control configurations), approximately 2,000 feet upstream of the start of the taper, and approximately 5,500 feet upstream of the start of the taper. The counters/stations were referred to as counter 1, counter 2, and counter 3, respectively. The counters were initially activated on a 24-hour/7-day basis to determine the peak hours of congestion. Once these were identified, traffic counters were activated only on the days of heaviest congestion to conserve battery power. Counters summarized volume data in 15-minute intervals.

Queue Lengths and Travel Times

Probe vehicles with distance-measuring instruments (DMIs) were used to collect queue lengths and travel times. These data were used to determine the travel time a motorist experienced while waiting in the work zone queue. Once peak hours had been identified using the traffic count data, site visits were planned to coincide with congested periods to take queue time and distance measurements. To collect data, the probe vehicle approached the end of the queue and recorded the time and distance to move from the beginning of the queue to the lane closure taper (considered to be at the arrow panel). Two vehicles were used to collect these data, depending on availability of personnel. The two vehicles were staggered so changes in traffic conditions could be captured. The probe vehicles traveled in only the open lane and did not change lanes during data collection. This was done to maintain a consistency in the data collection process and represent a “worst case” travel time for both types of traffic control. Queues and travel times were always longer in the open lane, and this type of data collection represented a driver who stayed in the open lane throughout his or her time in queue.

Reduce Data

Volume Data

The volume data, as recorded by each counter, were aggregated in 15-minute increments. Once the data had been entered into the spreadsheet, any 15-minute increments that did not include a complete set of data (i.e., volume readings for all counters) were eliminated. This was necessary to provide for accuracy in the analysis phase.

Distance Measuring Instrument Data

As with the volume data, DMI data were entered into a spreadsheet for manipulation. The data recorded by the DMI during field tests included the date, the start time at which the DMI-equipped vehicle entered the end of the queue, the queue length, and the time in queue. For each site, these data were entered into separate columns. Once entered, a separate column was

added for the 15-minute block in which the start time fell. This allowed the DMI data to be matched to its corresponding volume data. The DMI data were also sorted in ascending order by date.

Volume and DMI Data Matching

Once volume and DMI data had been reduced individually, the data were matched using dates and times as keys. Often, there was more than one DMI reading for each 15-minute block because there was typically more than one DMI-equipped vehicle operating during the period of study. To differentiate the data and gain a more accurate representation of what was going on in the field, the demand volume data were calibrated to the actual start times. Calibration was accomplished using a form of interpolation that took into account the demand volume 15 minutes prior to the DMI-equipped vehicle entering the queue (existing demand).

Existing demand was determined through consideration of known 15-minute demand volumes and the ratio of time spent within the 15-minute blocks. The 15-minute time period prior to entering the queue always straddled two blocks. Figure 1 illustrates the procedure when both time periods of interest straddle 15-minute blocks. The calculations A and B were used to find the existing demand. Since counters collected volume data in 15-minute blocks, A was found by multiplying the demand volume for 1445 to 1500 by the ratio of time spent in that block per 15 minutes. B was found by multiplying the demand volume for 1500 to 1515 by the ratio of time spent in that block per 15 minutes. A and B added together represented the existing demand. This procedure was used for each data point.

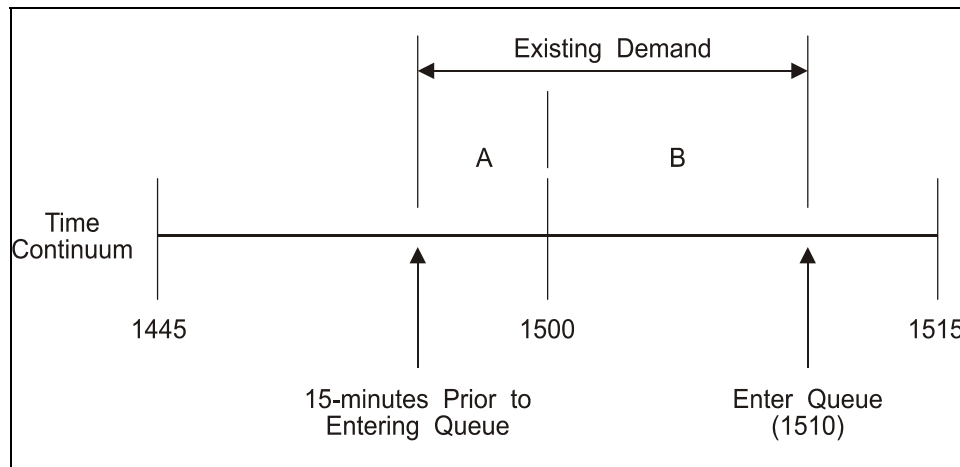

Figure 1. Volume Interpolation Procedure

For example, a vehicle enters the queue at time 1510. If the volume measured from 1445 to 1500 is 300 vehicles, and the volume measured from 1500 to 1515 is 270 vehicles, then the volume from 1455 to 1510 needs to be determined to find the demand volume in the prior 15 minutes. The interpolated demand volume for this scenario would then be:

$$\text{Volume} = \frac{5}{15}(300) + \frac{10}{15}(270) = 280$$

Data Analysis

To determine whether the late merge was a more effective treatment than the MUTCD treatment, the analysis focused on the MOEs already identified: percentage of vehicles in the closed lane, throughput volume, and time in queue. The data collected were tested for significant differences between the average percentage of vehicles in the closed lane, throughput, and time in queue for the late merge and the traditional lane closure. Crash data were also examined from before and after implementation of the late merge to determine whether it improved safety.

One-way ANOVA

For the percentage of vehicles in the closed lane and throughput volume, a one-way ANOVA was used for each variable. These tests were chosen since MUTCD and late merge data could be compared directly. That is, these variables could be assumed to be independent of changes in other variables such as demand volume.

Regression Models

For each field test site and each treatment, regression models were developed to predict the travel time in queue. Using stepwise regression, the variables examined to develop the models were:

1. demand volume
2. throughput
3. percentage of vehicles in the closed lane
4. existing demand
5. volume in the closed lane
6. volume in the open lane.

Interactions of these variables were also reviewed. Linear and quadratic equations were examined. Significant differences between the late merge and MUTCD time in queue were identified by examining the confidence intervals of the respective regression equation coefficients. If the confidence intervals did not overlap for the two scenarios, they were significantly different. Regression models were necessary over simple one-way ANOVA since a difference in time in queue could have been attributable to a difference in demand for those periods of time. This would not necessarily be an indication of improved flow at the site but rather of changes in the traffic demands. The models allowed for a context-sensitive examination of the variables.

Crash Statistics

Crash data were pulled from VDOT's Highway Traffic Records Information System (HTRIS) database. Only crashes occurring during the study period, before and after the implementation of the late merge, were pulled. The type and frequency of crashes were studied to determine whether the late merge had affected the safety of the work zone. Since the traffic control was in place for only several months, it was unlikely that significant trends in crash

history would be observed. However, this information might provide some indication of the potential safety of the late merge.

Alternative Assessment and Guideline Development

The results of the field and simulation analyses were examined to determine under what conditions a particular traffic control strategy should be used. The simulations provided an opportunity to examine many more alternatives than were possible through field-testing, and the field-testing served to provide valuable information on the real-world application of the strategy. A series of preliminary guidelines for the application of the late merge was developed. This offered the opportunity to gauge when the late merge would be most suitable at a location and also what areas required further research.

RESULTS

Literature Review

Overview

Several recent studies have indicated a growing need to find more efficient and safer ways to process traffic through highway work zones. Pal and Sinha showed that for all types of crashes (fatal, non-fatal injury, and property damage), the average crash rates were much higher for work zones than for similar facilities that were not being rehabilitated.¹⁰ In another synthesis, Ha and Nemeth showed that the crash rate at a site increased anywhere from 7 to 119 percent after a work zone was installed.¹¹ Garber and Zhao found that work zone crashes involved not only a higher proportion of fatalities, but also a higher proportion of multi-vehicle crashes.¹² In addition, their analysis of police crash records showed that 70 percent of all crashes in work zones occurred in the activity area, clearly demonstrating that the safety of not only motorists is in jeopardy, but the safety of construction workers is also of great concern. Motorists further corroborate safety concerns. Benekohal, Shim, and Resende found that 90 percent of truck drivers in a survey conducted in Illinois felt that driving through work zones was more hazardous than driving in other areas.¹³

Work zones can also prove costly in terms of time delays and fuel consumption. The HCM shows that if the arriving demand begins to exceed the available capacity of a work zone, a queue will begin to form upstream of the reduced-capacity section, resulting in increased delays and travel times.⁸ The typical capacities shown in the HCM for lane closures at long-term work zones are summarized in Table 2. Capacity values can also be affected by the intensity of the work (i.e., number of workers on site, number and size of work vehicles in use, proximity of work to the travel lanes in use, and unusual types of work).⁸ Plummer et al. showed how as queues form, energy consumption becomes a factor of additional idling time and additional speed change cycles.¹⁴

Table 2. HCM Measured Average Capacities for Lane Closures⁸

No. of Lanes		No. of Studies	Average Capacity (vphpl)
Total	Open		
3	1	7	1,170
2	1	8	1,340
5	2	8	1,370
4	2	4	1,480
3	2	9	1,490
4	3	4	1,520

Aggressive driving is often a contributor to, and sometimes a direct result of, safety and efficiency concerns at work zones. Aggressive driving is especially prevalent at work zone lane closures.³ Road rage is an extreme form of aggressive driving that results in “active hostility directed toward a specific driver.”¹⁵ Walters and Cooner explained that the very nature of lane closures tends to separate drivers into two camps: those that vacate the closed lane as soon as possible and those that stay in the closed lane as long as possible to avoid waiting in the queue, a movement called “queue jumping.” Although both approaches are legal, their use naturally creates friction between the two types of drivers, sometimes resulting in not only aggressive driving, but also strategic driving seeking to defeat the other camp’s chosen style. A study by Wells-Parker et al. showed that nearly 20 percent of drivers surveyed had kept someone from entering a lane out of anger.¹⁵ An example of this type of strategic driving is “lane straddling,” where a truck straddles both lanes or two truck drivers drive side by side in an effort to keep vehicles from queue jumping. This action may actually reduce the throughput at the merge point because of the large gaps between vehicles that often form.⁵

Although the MUTCD¹ and the VAWAPM² specify traffic control layouts for lane closures, these TCPs could be changed to improve safety and efficiency. A number of studies have focused on methods to improve merging operations at work zones since lane closures have the potential to reduce capacity and increase delay significantly. From these studies, the early merge and late merge concepts emerge as two of the most promising methods to alleviate safety and capacity concerns at work zones. Each strategy is designed to improve merging operations at lane closures associated with work zones; however, their approaches to solving this problem are quite different.

Early Merge Strategy

The early merge concept follows a more traditional approach to solving the problems associated with merging operations. It tries to promote earlier merging in advance of work zone lane closures to lower the potential for merging friction at the merge point of a lane closure. This is accomplished through the use of additional signage or supplementary control measures further upstream. A disadvantage of this strategy is that it requires that traffic control be placed further upstream of a lane, which can make maintenance of traffic control more difficult. The early merge can take two forms: static or dynamic.

Static Form

The static form of the early merge does not change in real time in response to traffic conditions. The static form typically includes additional LANE CLOSED signs placed upstream of the lane closure at 1-mile intervals.¹⁶ In theory, the static early merge reduces the chances of rear-end collisions by giving the driver advanced warning of potential slowing of traffic. Additional static methods of promoting earlier merging include the use of supplementary control measures.

Bernhardt, Virkler, and Shaik explored several supplementary control measures to promote earlier merging.⁴ They tested the effectiveness of white lane drop arrows, the Wizard Work Zone Alert and Information Radio by TAFCON Industries, and orange rumble strips as a supplement to the standard lane merge configuration. The lane drop arrows and rumble strips were used to provide additional reinforcement about the presence of the lane drop. The Wizard system was used primarily to target information specifically at truck drivers. The system is similar to a highway advisory radio, and it was used to broadcast lane closure information on Channel 19, the channel most commonly used by truckers. CB users tuned to this channel automatically heard the warning message, and no additional action on the part of truck drivers was required to hear the message.

Each control measure was installed at a work zone on I-70 in Columbia, Missouri, a four-lane highway with two lanes in each direction and one lane closed. Traffic counters were used to collect information on speeds, volumes, lane distributions, and classifications in 15-minute intervals. These data were collected for at least 1 day before and 1 day after each traffic control device was installed at the work zone. All three devices helped promote early merging and led to a decrease in the average speeds of vehicles approaching the work zone.

Orange rumble strips increased the number of vehicles in the open lane at the start of the work zone taper during congested conditions by 10.2 percent. For uncongested conditions, the mean speeds in the closed lane decreased by 16.1 mph. Uncongested 85th percentile speeds decreased by 6.9 mph, and the mean speed of the fastest 15 percent of vehicles decreased between 6.7 mph and 15.1 mph.

During congested conditions, lane drop arrows led to a 4.2 percent increase in the number of vehicles in the open lane at the work zone taper. Mean speeds decreased by 6.1 mph under congested conditions. The number of vehicles below the speed limit under uncongested conditions increased by 14.8 percent. Finally, a decrease of 10.3 mph in the mean speeds of the fastest 15 percent of vehicles occurred under congested conditions.

The Wizard led to an increase in the number of vehicles in the open lane by 12.4 percent under uncongested conditions. The number of vehicles below the speed limit increased by 11.7 percent under uncongested conditions.

Dynamic Form

The dynamic form of the early merge uses real-time measurements of traffic conditions to establish a variable no-passing zone in advance of the work zone.¹⁷ The Indiana Lane Merge System (ILMS) is one example of a dynamic early merge strategy. The ILMS has been evaluated in three studies.^{5,17,18} It uses queue detectors mounted on DO NOT PASS WHEN FLASHING signs, making queue jumping an illegal activity in times of congestion. When a queue is detected next to a sign, the next closest sign upstream is activated to create the no-passing zone. Figure 2 illustrates this concept.

In 1999, the University of Nebraska published a study of the ILMS conducted near Remington, Indiana, on I-65.⁵ For this study, the work zone involved closure of the right lane. The location was observed under uncongested conditions. Data were collected over 4 days with three video cameras and laser speed measurement devices. This equipment was used to collect data for the determination of traffic volumes, speeds, conflicts, lane distribution, flow, and time headway.

The ILMS was further studied by Purdue University in a report published in 2001.¹⁷ This study was also conducted on I-65, but near West Lafayette, Indiana. This location was observed under congested and uncongested conditions with and without the ILMS in place. The study included analysis of the capacity effect of the ILMS and development of conflict frequency models. Data were collected 4 months in 1999. Conflict data were collected using two cameras, both mounted to a telescoping mast attached to a van, and multiple loop detectors.

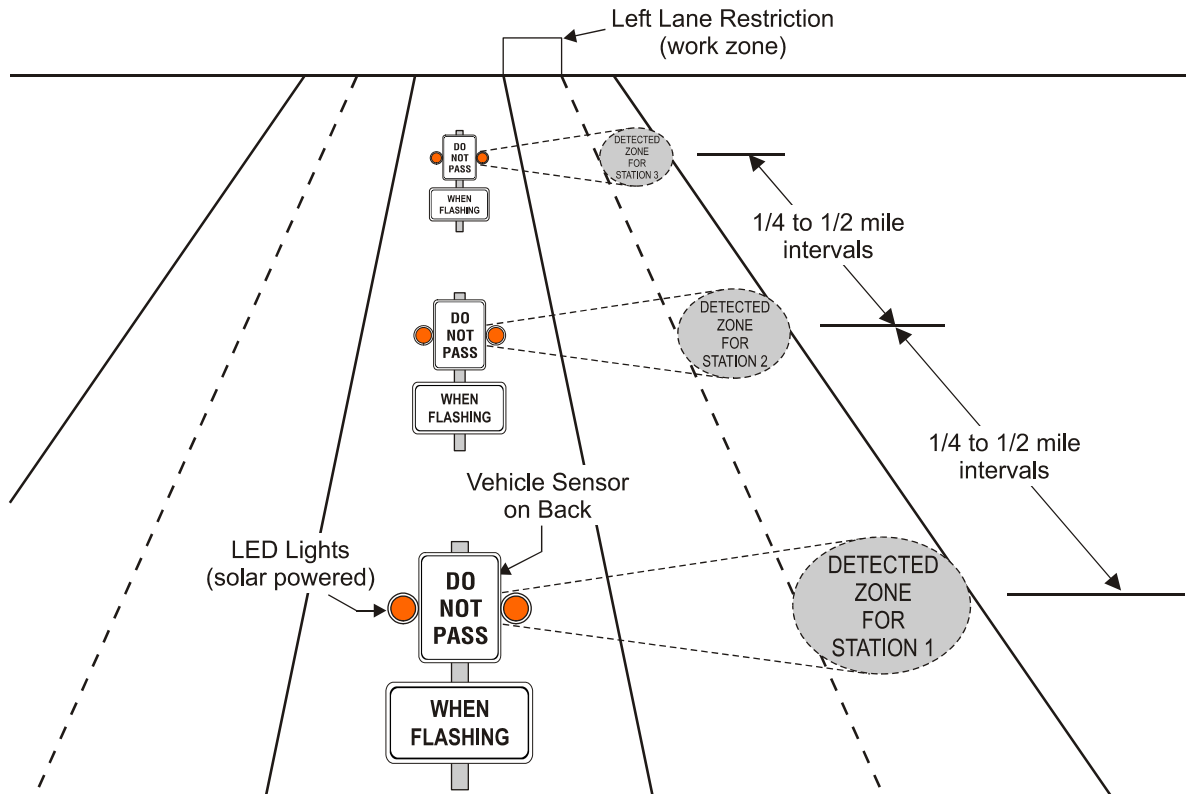

Figure 2. Indiana Lane Merge System

The ILMS was also studied at Wayne State University.¹⁸ Referred to as the Michigan Lane Merge Traffic Control System (LMTCS), the strategy was tested at four sites and compared to four control sites. Two control sites were static versions of the LMTCS (requires manual activation of DO NOT PASS WHEN FLASHING signs), and the other two implemented the traditional MUTCD merge. Each implementation of the LMTCS and the control sites were on freeways with two lanes in each direction. All work zones had left-lane closures for consistency. Data collection involved travel time and delay studies conducted using the floating car method. Also recorded were the locations and durations of stopped time delay through the advance warning area, status of the signs at LMTCS test sites, aggressive driver behavior, vehicle merge locations, and presence of law enforcement officials. Traffic volume and speed data were recorded with a radar gun and video camera to determine speed, traffic flow, density, and monitor driver behavior for each run.

The results of studies on the dynamic early merge concept are mixed. The Wayne State study¹⁸ showed an increase in average operating speeds, a decrease in average delay (a total savings of 49 vehicle hours of delay per hour), and a decrease in the number of aggressive driving maneuvers during the peak hour (from 73 to 33). The Nebraska study⁵ showed few forced merges with the ILMS (4 in 16 hours worth of video data), yet it was unclear whether this was a result of the ILMS or if it was due to the lack of congested conditions during the study. The Nebraska study estimated that the ILMS created a slight improvement in capacity over the standard MUTCD merge control, raising capacity from 1,460 to 1,540 vphpl. The other studies failed to show that the ILMS resulted in higher capacity. The Purdue University study¹⁷ showed that the strategy decreased capacity by 5 percent, and the Wayne State Study¹⁸ showed virtually no difference in capacity. The Purdue authors attributed the worsening of capacity to motorists' lack of familiarity with the system. It should be noted that the data in these studies were collected under much different conditions. The Purdue study collected data during congested and uncongested conditions, and the Nebraska study collected data only for uncongested conditions. The Purdue study also spanned several months, and the Nebraska study was limited to 4 days.

Late Merge Strategy

As with the early merge, the late merge can take on static and dynamic forms.

Static Form

According to a University of Nebraska study, the Pennsylvania Department of Transportation (PennDOT) introduced the static form of the late merge to reduce incidents of aggressive driving and road rage at merge points.⁵ In addition to the standard (MUTCD) lane closure signage, the PennDOT traffic control plan calls for USE BOTH LANES TO MERGE POINT signs on either side of the road 1.5 miles upstream of the merge point and MERGE HERE TAKE YOUR TURN signs near the beginning of the taper on both sides. Figure 3 illustrates the late merge traffic control used in Pennsylvania.

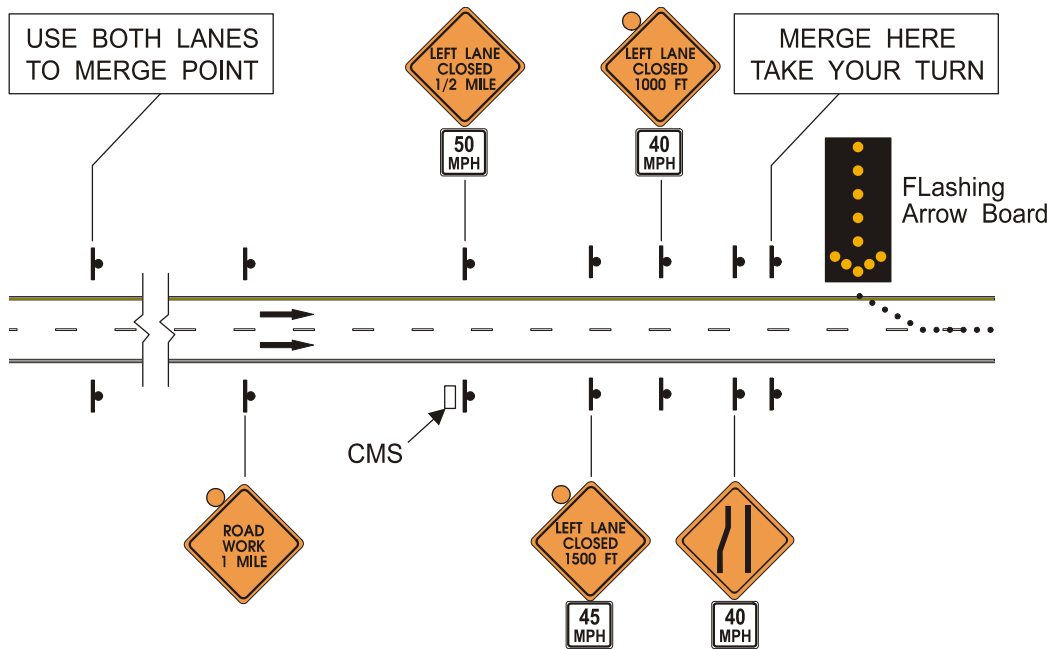

Figure 3. PennDOT Late Merge Concept

The University of Nebraska examined PennDOT’s late merge strategy in detail as part of the study that examined the ILMS.⁵ As with the ILMS, the Nebraska data were collected over 4 days using three video cameras and laser speed measurement devices. The equipment was used to collect traffic volumes, lane distributions, speeds, density, driver behavior, traffic conflicts, flow, and time headways.

The Nebraska study of a 2-to-1 lane reduction scenario showed that the late merge resulted in 75 percent fewer forced merges and an increased capacity (throughput) of 1,730 pcp/h versus 1,460 pcp/h for the standard MUTCD lane merge. However, this study suggested that an effective signing plan for the late merge must be researched to restructure drivers’ expectancies and maximize the potential of the concept. The study also concluded that trucks had more difficulty merging from left to right than from right to left.

The Texas Transportation Institute (TTI) further explored the late merge concept in a 3-to-2 lane closure scenario.³ Because of logistical problems, data collection for this project was limited to 1 day under standard lane closure conditions and 1 day under the late merge scenario. TTI used three cameras to record volume distribution by lane and field data collection personnel to monitor queue length.

Results of the TTI study showed for a single field test, the late merge delayed the onset of congestion at the work zone by 14 minutes. Queue length was also reduced (7,800 to 6,000 feet), but this may have been due to early removal of the lane closure. An analysis of volumes by lane showed that a larger percentage of vehicles used the open lane with the late merge in place and that more vehicles were able to pass through the merge point.

The University of Nebraska conducted a driver survey of the late merge strategy to determine the opinions of drivers regarding its applicability.¹⁹ This study field-tested the late merge at an actual construction work zone and surveyed drivers at a rest area downstream of the activities. It was conducted at a work zone in Pennsylvania where the left lane of two lanes was closed.

Sixty percent of truck drivers versus 22 percent of car drivers stated they experienced or observed other drivers having difficulty merging. A large percentage of car drivers blamed this on congestion, whereas truck drivers blamed this on “cars speeding ahead to the merge point in the closed lane.” Those who did not have difficulty merging attributed it largely to a low traffic volume. Nearly all car and truck drivers saw the late merge signs, but 73 percent of truck drivers did not believe the signs actually worked whereas 60 percent of car drivers believed they did. Most of the former primarily blamed drivers for not following the instructions provided by the signs. Those (56 percent) supportive of the late merge largely attributed its success to “not having to worry about changing lanes.” As for standard lane closure merging operations, most drivers said the biggest problem was drivers speeding ahead and cutting in front of them.

Dynamic Form

As a follow up to their research, McCoy and Pesti authored a report proposing the dynamic, traffic-responsive late merge concept.¹⁶ They argued that the early and late merges provide for safer merging operations over the standard merge. Of the two concepts, they found the late merge to have the highest capacity and to reduce congestion delay, whereas the early merge actually increased congestion delay. Thus, the late merge was preferred during periods of congestion. However, during periods of high-speed, low-volume conditions, the authors expressed concern over driver confusion at the merge point with the late merge in place. To resolve this situation, they proposed a dynamic late merge in which the late merge would be employed only at times of high congestion. This could be accomplished using variable message signs that would be activated and deactivated with traffic detectors, similar to the dynamic early merge.

Although McCoy and Pesti did not include a field test of the dynamic late merge, the concept is being evaluated in several studies. These include tests in Kansas as part of the Midwest States Smart Work Zone Deployment Initiative and in Maryland and Minnesota by their departments of transportation. At the writing of this report, detailed results from these ongoing studies were not available, but preliminary results from Minnesota indicated a reduction in queue lengths and traffic conflicts.

Comparison of Early and Late Merge Strategies

Table 3 presents a summary of the observed measures of effectiveness for each scenario. A superior method is not readily apparent, and the extent of the advantages for each strategy is not clear. Possible reasons include short durations of study, a limited number of study sites, and a lack of variety in the traffic characteristics of the sites.

Table 3. Comparison of MUTCD, Early, and Late Merge Strategies^a

Factor	Standard MUTCD Closure	Late Merge		Early Merge	
		Static	Dynamic	Static	Dynamic
Capacity (pcph)	1,460 ⁵ 1,320 ¹⁷	1,730 ⁵	1,820 ¹⁶ (estimated)	No data available	Conflicting data: Decreased 5% in one study, ¹⁷ 1,540 capacity in another ⁵
Forced Merges	20/hr ⁵	Decreased 75% ⁵	No data available	Decreased ⁴	1/day ⁵
Cost Impact		Increases \$6/day	Increases \$120/day ⁵	No data available	Increases \$120/day ⁵
Lane Distribution		Volume increased 30% in closed lane ⁵	No data available	Volume increased 12.4% in open lane ^{4, a}	Volume increased 20% in open lane ⁵
Mean Speed (vs. standard MUTCD)		Decreased 7 mph (uncongested) ⁵ Decreased 32 mph (congested)	No data available	Decreased 16.1 mph (uncongested) ^{4, b}	Decreased 2 mph (uncongested) ⁵
Queue Length		Decreased 50% ⁵ Decreased 23% ³	No data available	No data available	No data available

^a Superscript numbers refer to the reference for the pertinent study.

^b Test results based on inclusion of white lane drop arrows and Wizard.

^c Test results based on inclusion of orange rumble strips.

TCP Development

As part of the TCP development process, designs and specifications for the late merge traffic control signs were finalized. Computer-generated drawings of the signs are provided in Figures 4 and 5. The specifications for the signs as manufactured are included in Tables 4 and 5.



Figure 4. STAY IN LANE TO MERGE POINT Sign

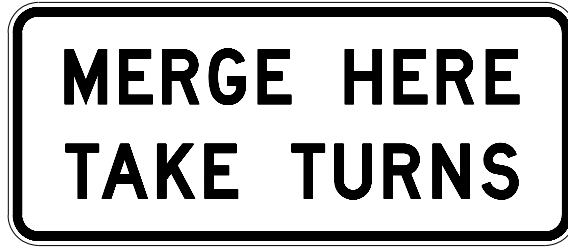

Figure 5. MERGE HERE TAKE TURNS Sign

Table 4. Specifications for STAY IN LANE TO MERGE POINT Sign

Message	Specification
Background color	Orange
Font color	Black
Font height	10 or 8 in
Font type	Series E(M)
Border width	2 in/black
Height	5 ft 6 in (10-in letters) 4 ft 4 in (8-in letters)
Width	14 ft (10-in letters) 11 ft 6 in (8-in letters)

Table 5. Specifications for MERGE HERE TAKE TURNS Sign

Message	Specification
Background color	White
Font color	Black
Font height	10 or 8 in
Font type	Series E(M)
Border width	2 in/black
Height	4 ft (10-in letters) 3 ft 2 in (8 -n letters)
Width	11 ft 6 in (10-in letters) 9 ft 6 in (8-in letters)

Simulation Calibration Results

MUTCD Traffic Control

Stepwise regression was used to develop the mathematical relationships to predict lane distributions approaching the work zone. Models were developed based on uncongested conditions reported in previous studies, including studies by Walters,³ Bernhardt,⁴ McCoy,⁵ Finley,⁶ and Fontaine,⁷ Using the factors listed previously, based on 23 observations, the stepwise regression produced the following model:

$$\text{Percentage of vehicles in the closed lane} = 0.016 \times \text{Distance from taper}$$

This equation had an R^2 of 0.953. The model was implemented in the simulations through the placement of decision arrows as discussed in the Methodology. Table 6 shows the results of the model validation. These results show that the capacities from the MUTCD simulations were consistent with HCM data for capacities.⁸ In the case of the 3-to-2 scenario, the model produced a throughput value that was on the low side of the HCM capacities although it was within the range of observed capacities for this configuration.

Table 6. MUTCD Model Validation Results⁸

Lane Configuration	VISSIM Throughput (vph)	HCM Capacity ⁸ (vph)	% Difference (VISSIM/HCM)
2-to-1	1269	1340	-6
3-to-1	1153	1170	-1.5
3-to-2	2304	2980	-22 ^a

^aObserved capacities for 3-to-2 closures have been shown to vary over a wide range (2,200 to 3,200 vph) depending on type of work.⁸

Late Merge Traffic Control

Unlike the MUTCD model, late merge simulation vehicles were not given merging instructions leading up to the taper. This was necessary to simulate the use of both lanes as called for by the late merge signs. Then, just before the taper, turn-taking behavior was simulated by using the priority rules function as prescribed by VISSIM. The late merge concept could be validated for only the 2-to-1 and 3-to-2 scenarios since only these two configurations had been tested in the field. The results are summarized in Table 7. Given the limited data available for comparison, these results were considered sufficient.

Table 7. Late Merge Validation Results^a

Lane Configuration	Free Flow Speed (mph)	VISSIM Throughput (vph)	Observed Capacities (vph)	% Difference (VISSIM/Observed)
2-to-1	60	1369	1450 ⁵	-5.6
	70	1376	1450 ⁵	-5.1
3-to-2	60	2599	2706 ³	-4.0
	70	2677	2706 ³	-1.1

^aSuperscript numbers refer to the appropriate reference.

Simulation Analysis Results

As discussed in the methodology, the factors examined in the simulations were traffic volumes, truck percentages, lane closure configuration, and desired free flow speeds. These factors and factor interactions were tested for their impact on throughput. An analysis using a full-factorial design was used. For the analysis, the simulation data were first examined by

treatment separately using univariate ANOVA and the LSD test for pairwise comparisons. The two treatments were then compared directly using the results of univariate ANOVA and according to lane configuration using one-way ANOVA.

MUTCD Statistical Analysis

In the case of the MUTCD treatment, all factors and factor interactions were shown to be significant in their impact on throughput. An overview of the results is shown in Table 8. Detailed results of the estimated marginal means are included in the sections that follow. Tables documenting the effects of two-factor interactions are included in Appendix A.

Table 8. Tests of Between-Subjects Effects for Throughput and MUTCD Control

Source	Type III Sum of Squares	df	Mean Square	F	Sig.
Corrected Model	1029176036.92	95.00	10833431.97	7892.01	0.00
Intercept	7151021377.51	1.00	7151021377.51	5209421.70	0.00
FFS	11492.02	1.00	11492.02	8.37	0.00
LANES	770674190.28	2.00	385337095.14	280712.83	0.00
PHV	19276772.48	3.00	6425590.83	4680.96	0.00
VOL	151442356.74	3.00	50480785.58	36774.56	0.00
FFS * LANES	91246.03	2.00	45623.02	33.24	0.00
FFS * PHV	58228.88	3.00	19409.63	14.14	0.00
LANES * PHV	2035979.28	6.00	339329.88	247.20	0.00
FFS * LANES * PHV	39635.11	6.00	6605.85	4.81	0.00
FFS * VOL	44973.58	3.00	14991.19	10.92	0.00
LANES * VOL	81031627.68	6.00	13505271.28	9838.41	0.00
FFS * LANES * VOL	42774.35	6.00	7129.06	5.19	0.00
PHV * VOL	3451352.76	9.00	383483.64	279.36	0.00
FFS * PHV * VOL	96296.03	9.00	10699.56	7.79	0.00
LANES * PHV * VOL	810264.79	18.00	45014.71	32.79	0.00
FFS * LANES * PHV * VOL	68846.91	18.00	3824.83	2.79	0.00
Error	3821622.57	2784.00	1372.71		
Total	8184019037.00	2880.00			
Corrected Total	1032997659.49	2879.00			

FFS = free flow speed, LANES = lane configuration, VOL = demand volume, PHV = percentage of heavy vehicles.

Free Flow Speed

When free flow speed was singled out for examination across all other factor combinations, univariate ANOVA showed a statistically significant increase in throughput when free flow speeds were increased from 60 to 70 mph. However, practically speaking, the 70 mph FFS increased throughput by only about 4 vph. It does not appear that FFS had a large practical impact on the throughput in the MUTCD simulations. The results are shown in Tables 9 and 10.

Table 9. Throughput Descriptive Statistics for MUTCD Control and Different Free flow Speeds

Free flow Speed (mph)	Mean Throughput (vph)	95% Confidence Interval	
		Lower Bound (vph)	Upper Bound (vph)
60	1573.75	1571.84	1575.67
70	1577.75	1575.83	1579.66

Table 10. Pairwise Comparisons of Throughput for MUTCD Control and Different Free flow Speeds Based on Estimated Marginal Means

(I) Free-flow Speed (mph)	(J) Free-flow Speed (mph)	Mean Difference (I - J) (vph) ^a	Sig. ^b	95% Confidence Interval for Difference ^b	
				Lower Bound (vph)	Upper Bound (vph)
60	70	-4.00	0.00	-6.70	-1.29
70	60	4.00	0.00	1.29	6.70

^aAll mean differences were significant at the 0.05 level.

^bAdjustment for multiple comparisons: least significant difference (equivalent to no adjustments).

Lane Configuration

Next, lane configuration was examined across all other factor combinations. Univariate ANOVA showed a statistically significant difference among all three lane configurations. The mean throughput for the 3-to-2-lane configuration was the highest, followed by the 2-to-1 configuration, and then the 3-to-1 configuration. This difference was expected considering the obvious capacity and demand volume differences of the three scenarios. Results are shown in Tables 11 and 12.

Percentage of Heavy Vehicles

When percentage of heavy vehicles was examined across all other factor combinations, univariate ANOVA showed a statistically significant difference among the four percentage levels. As the percentage was increased, the mean throughput decreased. In quantitative terms, when heavy vehicles were increased from 0 percent to 30 percent, throughput decreased 13 percent. Again, this was expected given the lower performance characteristics of heavy vehicles. The results are shown in Tables 13 and 14.

Table 11. Throughput Descriptive Statistics for MUTCD Control and Different Lane Configurations

Lane Configuration	Mean Throughput (vph)	95% Confidence Interval	
		Lower Bound (vph)	Upper Bound (vph)
2-to-1	1269.22	1266.88	1271.57
3-to-1	1153.76	1151.41	1156.10
3-to-2	2304.28	2301.93	2306.62

Table 12. Pairwise Comparisons of Throughput for MUTCD Control and Different Lane Configurations

(I) Lane Configuration	(J) Lane Configuration	Mean Difference (I - J) (vph) ^a	Sig. ^b	95% Confidence Interval for Difference ^b	
				Lower Bound (vph)	Upper Bound (vph)
2-to-1	3-to-1	115.47	0	112.15	118.78
	3-to-2	-1035.05	0	-1038.37	-1031.74
3-to-1	2-to-1	-115.47	0	-118.78	-112.15
	3-to-2	-1150.52	0	-1153.83	-1147.20
3-to-2	2-to-1	1035.05	0	1031.74	1038.37
	3-to-1	1150.52	0	1147.20	1153.83

^aAll mean differences were significant at the 0.05 level.

^bAdjustment for multiple comparisons: least significant difference (equivalent to no adjustments).

Table 13. Throughput Descriptive Statistics for MUTCD Control and Different Percentages of Heavy Vehicles

% Heavy Vehicles	Mean Throughput (vph)	95% Confidence Interval	
		Lower Bound (vph)	Upper Bound (vph)
0	1690.80	1688.09	1693.51
10	1604.02	1601.32	1606.73
20	1539.21	1536.51	1541.92
30	1468.97	1466.26	1471.68

Table 14. Pairwise Comparisons of Throughput for MUTCD Control and Different Percentages of Heavy Vehicles Based on Estimated Marginal Means

(I) % Heavy Vehicles	(J) % Heavy Vehicles	Mean Difference (I - J) (vph) ^a	Sig. ^b	95% Confidence Interval for Difference ^b	
				Lower Bound (vph)	Upper Bound (vph)
0	10	86.78	0	82.95	90.61
	20	151.59	0	147.76	155.42
	30	221.83	0	218.00	225.66
10	0	-86.78	0	-90.61	-82.95
	20	64.81	0	60.98	68.64
	30	135.05	0	131.23	138.88
20	0	-151.59	0	-155.42	-147.76
	10	-64.81	0	-68.64	-60.98
	30	70.24	0	66.41	74.07
30	0	-221.83	0	-225.66	-218.00
	10	-135.05	0	-138.88	-131.23
	20	-70.24	0	-74.07	-66.41

^aAll mean differences were significant at the 0.05 level.

^bAdjustment for multiple comparisons: least significant difference (equivalent to no adjustments).

Demand Volume

Demand volume was examined across all other factor combinations. Univariate ANOVA showed a statistically significant difference when comparing the four levels of demand volume. However, the difference was limited to the comparison of the relatively low demand volume of 500 vehicles as compared to the other volume levels (1,000, 1,500, 2,000 vphpl). Although the differences between the other scenarios were statistically significant, there was not a large practical difference between these throughputs. This indicates that the simulated work zones reached capacity at or before 1,000 vphpl were introduced into the system, and thus volume levels of 1,500 and 2,000 vphpl did not affect mean throughput. Results are shown in Tables 15 and 16.

Table 15. Throughput Descriptive Statistics for MUTCD Control and Different Demand Volumes

Demand Volume (vphpl)	Mean Throughput (vph)	95% Confidence Interval	
		Lower Bound (vph)	Upper Bound (vph)
500	1178.60	1175.90	1181.31
1000	1708.19	1705.49	1710.90
1500	1712.29	1709.58	1715.00
2000	1703.92	1701.21	1706.63

Table 16. Pairwise Comparisons of Throughput for MUTCD Control and Different Demand Volumes Based on Estimated Marginal Means

(I) Demand Volume (vphpl)	(J) Demand Volume (vphpl)	Mean Difference (I - J) (vph) ^a	Sig. ^b	95% Confidence Interval for Difference ^b	
				Lower Bound (vph)	Upper Bound (vph)
500	1000	-529.59	0	-533.42	-525.76
	1500	-533.68	0	-537.51	-529.86
	2000	-525.32	0	-529.15	-521.49
1000	500	529.59	0	525.76	533.42
	1500	-4.10	0.04	-7.92	-0.27
	2000	4.27	0.03	0.44	8.10
1500	500	533.68	0	529.86	537.51
	1000	4.0958	0.04	0.27	7.92
	2000	8.37	0	4.54	12.20
2000	500	525.32	0	521.49	529.15
	1000	-4.270	0.03	-8.10	-0.44
	1500	-8.37	0	-12.20	-4.54

^aAll mean differences were significant at the 0.05 level.

^bAdjustment for multiple comparisons: least significant difference (equivalent to no adjustments).

Free Flow Speed by Lane Configuration

The interaction between free flow speed and lane configuration was examined across all other factor combinations. When corresponding lane configurations for each free flow speed were compared, throughput was significantly lower for the 3-to-1-lane configuration at 70 mph. However, throughput was significantly higher at 70 mph with the 3-to-2-lane configuration. In practical terms, the differences were small, and one can conclude that free flow speed had a negligible impact on throughput. Results are shown in Table A-1 in Appendix A.

Free Flow Speed by Percentage of Heavy Vehicles

The interaction between free flow speed and percentage of heavy vehicles was examined across all other factor combinations. When comparing corresponding heavy vehicle percentages for each free flow speed, there was a statistically significant difference only when no heavy vehicles were present. In practical terms, this difference was small. Here again, free flow speed had minimal impact on throughput. Table A-2 in Appendix A provides the results.

Lane Configuration by Percentage of Heavy Vehicles

Across all other factor combinations, the interaction between percentage of heavy vehicles and lane configurations showed a statistically significant and practically significant difference for all combinations. A high percentage of heavy vehicles reduced mean throughput, regardless of lane configuration, as shown in Table A-3 in Appendix A.

Free Flow Speed by Demand Volume

The interaction between free flow speed and demand volume was also examined across all other factor combinations. Overall, free flow speed did not influence throughput when broken out by volume, as indicated in Table A-4 in Appendix A.

Lane Configuration by Demand Volume

Across all other factor combinations, for all volumes there was a statistically significant difference among corresponding volumes under different lane configurations. This interaction continued to show the influence of lane configuration and was consistent with trends in throughput for various volume levels, as indicated in Table A-5 in Appendix A.

Percentage of Heavy Vehicles by Demand Volume

Finally, the interaction between percentage of heavy vehicles and demand volume across all other factor combinations was examined. For all corresponding volumes, throughput showed a statistically significant decrease as the percentage of heavy vehicles increased. Previous trends regarding the effects of volume levels were continued, as indicated in Table A-6 in Appendix A.

Three- and Four-factor Interactions

The three- and four-factor interactions for the variables examined reflected the same trends shown with the single- and two-factor analyses with few exceptions. The exceptions were on a single-event basis and did not appear to reflect any trends in the data.

Summary of MUTCD Statistical Analysis

Table 17 summarizes the results of the statistical analysis for the MUTCD control. The range of impacts for each main effect is shown. The information should provide a general indication of which main effects created practical changes in throughput. Not surprisingly, heavy vehicle percentage had a much larger impact on throughput than free flow speed or demand volume (once over capacity).

Table 17. Summary of MUTCD Throughput Statistical Analysis

Factor	Range	Impact
Free flow speed	60 to 70 mph	16 vph
Heavy vehicle percentage	0 to 30 percent	256 vph
Demand volume (above capacity)	1000 to 2000 vph	12 vph

Late Merge Statistical Analyses

Unlike the results of the MUTCD simulations, not all factor interactions were significant in their impact on throughput. Interactions that were not significant were limited to interactions involving three and four variables. An overview of the results of the significant factors and factor interactions is shown in Table 18. The sections that follow describe significant factors. Appendix B includes analysis results for two-factor interactions.

Free Flow Speed

When free flow speed was singled out for examination across all other factor combinations, univariate ANOVA showed a statistically significant increase in throughput when free flow speeds were increased from 60 to 70 mph. As with the MUTCD treatment, practically speaking, the difference in mean throughput volumes was small, at roughly 9 vph. Results are shown in Tables 19 and 20.

Lane Configuration

When lane configuration was examined across all other combinations, univariate ANOVA showed a statistically significant difference among all the three lane configurations. However, unlike the MUTCD treatment, the 3-to-1 configuration had a higher mean throughput than the 2-to-1 configuration. Still, the difference in mean throughput values for the 2-to-1 and 3-to-1 lane configurations was only about 11 vph. Results are shown in Tables 21 and 22.

Table 18. Tests of Between-Subjects Effects for Throughput and Late Merge Control

Source	Type III Sum of Squares	df	Mean Square	F	Sig.
Corrected Model	880151968.27	95.00	9264757.56	2566.38	0.00
Intercept	7491436647.73	1.00	7491436647.73	2075163.78	0.00
FFS	54444.61	1.00	54444.61	15.08	0.00
LANES	639000821.08	2.00	319500410.54	88503.14	0.00
PHV	16077534.24	3.00	5359178.08	1484.52	0.00
VOL	115503903.15	3.00	38501301.05	10665.04	0.00
FFS * LANES	57225.83	2.00	28612.92	7.93	0.00
FFS * PHV	96228.49	3.00	32076.16	8.89	0.00
LANES * PHV	5528451.57	6.00	921408.59	255.23	0.00
FFS * LANES * PHV	41459.18	6.00	6909.86	1.91	0.07
FFS * VOL	54798.50	3.00	18266.17	5.06	0.00
LANES * VOL	102158765.13	6.00	17026460.85	4716.41	0.00
FFS * LANES * VOL	12544.41	6.00	2090.74	0.58	0.75
PHV * VOL	1040438.93	9.00	115604.33	32.02	0.00
FFS * PHV * VOL	35010.12	9.00	3890.01	1.08	0.38
LANES * PHV * VOL	398109.67	18.00	22117.20	6.13	0.00
FFS * LANES * PHV * VOL	92233.36	18.00	5124.08	1.42	0.11
Error	10050368.00	2784.00	3610.05		
Total	8381638984.00	2880.00			
Corrected Total	890202336.27	2879.00			

FFS = free flow speed, LANES = lane configuration, VOL = demand volume, PHV = percentage of heavy vehicles.

Table 19. Throughput Descriptive Statistics for Late Merge Control and Different Free Flow Speeds

Free flow Speed (mph)	Mean Throughput (vph)	95% Confidence Interval	
		Lower Bound (vph)	Upper Bound (vph)
60	1608.47	1605.37	1611.58
70	1617.17	1614.06	1620.27

Table 20. Pairwise Comparisons of Throughput for Late Merge Control and Different Free flow Speeds Based on Estimated Marginal Means

(I) Free flow Speed (mph)	(J) Free flow Speed (mph)	Mean Difference (I - J) (vph) ^a	Sig.	95% Confidence Interval for Difference ^b	
				Lower Bound (vph)	Upper Bound (vph)
60	70	-8.70	0.00	-13.09	-4.41
70	60	8.70	0.00	4.41	13.09

^aAll mean differences were significant at the 0.05 level.

^bAdjustment for multiple comparisons: least significant difference (equivalent to no adjustments).

Table 21. Throughput Descriptive Statistics for Late Merge Control and Different Lane Configurations

Lane Configuration	Mean Throughput (vph)	95% Confidence Interval	
		Lower Bound (vph)	Upper Bound (vph)
2-to-1	1274.47	1270.67	1278.28
3-to-1	1285.05	1281.25	1288.85
3-to-2	2278.94	2275.14	2282.74

Table 22. Pairwise Comparisons of Throughput for Late Merge Control and Different Lane Configurations Based on Estimated Marginal Means

(I) Lane Configuration	(J) Lane Configuration	Mean Difference (I - J) (vph) ^a	Sig.	95% Confidence Interval for Difference ^b	
				Lower Bound (vph)	Upper Bound (vph)
2-to-1	3-to-1	-10.58	0	-15.96	-5.20
	3-to-2	-1004.47	0	-1009.84	-999.09
3-to-1	2-to-1	10.58	0	5.20	15.96
	3-to-2	-993.89	0	-999.26	-988.51
3-to-2	2-to-1	1004.47	0	999.09	1009.84
	3-to-1	993.89	0	988.51	999.26

^aAll mean differences were significant at the 0.05 level.

^bAdjustment for multiple comparisons: least significant difference (equivalent to no adjustments).

Percentage of Heavy Vehicles

Examination of percentage of heavy vehicles across all other factor combinations showed a statistically significant difference when comparing the four levels of heavy vehicles. As with the MUTCD treatment, the percentage of heavy vehicles had a strong influence on the throughput of the system. However, the reduction in throughput as the percentage increased was slightly less (11 percent vs. 13 percent) when levels of 30 percent and 0 percent were compared. Results are shown in Tables 23 and 24.

Table 23. Throughput Descriptive Statistics for Late Merge Control and Different Percentages of Heavy Vehicles

% Heavy Vehicles	Mean Throughput (vph)	95% Confidence Interval	
		Lower Bound (vph)	Upper Bound (vph)
0	1714.25	1709.86	1718.64
10	1644.56	1640.17	1648.95
20	1579.16	1574.77	1583.55
30	1513.31	1508.92	1517.70

Table 24. Pairwise Comparisons of Throughput for Late Merge Control and Different Percentages of Heavy Vehicles Based on Estimated Marginal Means

(I) % Heavy Vehicles	(J) % Heavy Vehicles	Mean Difference (I - J) (vph) ^a	Sig.	95% Confidence Interval for Difference ^b	
				Lower Bound (vph)	Upper Bound (vph)
0	10	69.68	0	63.47	75.89
	20	135.08	0	128.87	141.29
	30	200.94	0	194.73	207.15
10	0	-69.68	0	-75.89	-63.47
	20	65.4	0	59.19	71.61
	30	131.25	0	125.04	137.46
20	0	-135.08	0	-141.29	-128.87
	10	-65.4	0	-71.61	-59.19
	30	65.85	0	59.64	72.06
30	0	-200.94	0	-207.15	-194.73
	10	-131.25	0	-137.46	-125.04
	20	-65.85	0	-72.06	-59.64

^aAll mean differences were significant at the 0.05 level.

^bAdjustment for multiple comparisons: least significant difference (equivalent to no adjustments).

Demand Volume

Finally, analysis of demand volume across all other factor combinations revealed a statistically significant difference when comparing the four levels of demand volume. Similar to the MUTCD treatment, the difference was limited to the comparison of the relatively low demand volume of 500 vehicles as compared to the other volume levels. Again, this demonstrated that the simulated work zones reached capacity after 1,000 vphpl were introduced into the system. Results are shown in Table 25 and 26.

Table 25. Throughput Descriptive Statistics for Late Merge Control and Different Demand Volumes

Demand Volume (vphpl)	Mean Throughput (vph)	95% Confidence Interval	
		Lower Bound (vph)	Upper Bound (vph)
500	1265.96	1261.56	1270.35
1000	1728.30	1723.91	1732.69
1500	1727.91	1723.52	1732.30
2000	1729.11	1724.72	1733.50

Table 26. Pairwise Comparisons of Throughput for Late Merge Control and Different Demand Volumes Based on Estimated Marginal Means

(I) Demand Volume (vphpl)	(J) Demand Volume (vphpl)	Mean Difference (I - J) (vph)	Sig.	95% Confidence Interval for Difference ^a	
				Lower Bound (vph)	Upper Bound (vph)
500	1000	-462.35 ^b	0	-468.56	-456.14
	1500	-461.96 ^b	0	-468.17	-455.75
	2000	-463.16 ^b	0	-469.37	-456.95
1000	500	462.35 ^b	0	456.14	468.56
	1500	0.39	0.90	-5.82	6.60
	2000	-0.81	0.80	-7.02	5.40
1500	500	461.96 ^b	0	455.75	468.17
	1000	-0.39	0.90	-6.60	5.82
	2000	-1.20	0.70	-7.41	5.01
2000	500	463.16 ^b	0	456.95	469.37
	1000	0.81	0.80	-5.40	7.02
	1500	1.20	0.70	-5.00	7.41

^aSignificant at the 0.05 level.

^bAdjustment for multiple comparisons: least significant difference (equivalent to no adjustments).

Free flow Speed by Lane Configuration

The first interaction examined was between free flow speed and lane configuration. Across all other factor combinations, when corresponding lane configurations for each free flow speed were compared, throughput was significantly higher at 70 mph with the 3-to-2-lane configuration. However, practically speaking, this was only about 20 vph. Again, free flow speed appeared to have a negligible impact on mean throughput. These results are summarized in Table B-1 in Appendix B.

Free Flow Speed by Percentage of Heavy Vehicles

The interaction between free flow speed and percentage of heavy vehicles was examined across all other factor combinations. When corresponding heavy vehicle percentages for each free flow speed were compared, there was a statistically significant difference only when no heavy vehicles were present. In practical terms, this difference was small, and thus the influence of free flow speed was small. These results are summarized in Table B-2 in Appendix B.

Lane Configuration by Percentage of Heavy Vehicles

Table B-3 in Appendix B summarizes the analysis of the interaction between lane configuration and percentage of heavy vehicles across all other factor combinations. This analysis revealed that there was a statistically significant difference for all combinations, following the same trend as seen with the MUTCD analysis.

Free Flow Speed by Demand Volume

The interaction between free flow speed and demand volume was examined across all other factor combinations and is summarized in Table B-4 in Appendix B. When corresponding volume levels between the two free flow speeds were compared, only volumes of 1,000 and 1,500 vphpl were shown to be significantly different (higher). In practical terms, again, this was a small number.

Lane Configuration by Demand Volume

Table B-5 in Appendix B summarizes the analysis of lane configuration by demand volume. Across all other factor combinations, for all volumes there was a statistically significant difference among corresponding volumes under different lane configurations.

Percentage of Heavy Vehicles by Demand Volume

The final interaction examined for the late merge treatment was between the percentage of heavy vehicles and demand volume across all other factor combinations. For all corresponding volumes, throughput showed a statistically significant decrease as the percentage of heavy vehicles increased. Table B-6 in Appendix B summarizes these results.

Three- and Four-Factor Interactions

Only the interaction among lane configuration, percentage of heavy vehicles, and demand volume was shown to be significant. Generally, this interaction reflected the same trends shown with the single- and two-factor analyses.

Summary of Late Merge Statistical Analysis

Table 27 summarizes the results of the statistical analysis for the late merge control. The range of impacts for each main effect is shown. Table 27 should provide a general indication of which main effects created practical changes in throughput. Not surprisingly, the percentage of heavy vehicles had a much larger impact on throughput than free flow speed or demand volume (once over capacity). However, the variation of throughput for the late merge was lower than for the MUTCD control for these variables.

Table 27. Summary of Late Merge Throughput Statistical Analysis

Factor	Range	Impact
Free flow speed	60 to 70 mph	9 vph
Heavy vehicle percentage	0 to 30%	201 vph
Demand volume (above capacity)	1,000 to 2,000 vph	1 vph

MUTCD vs. Late Merge

The MUTCD and late merge traffic control were compared directly to determine whether the late merge significantly improved throughput. The two merging strategies were compared

according to lane configuration. The two strategies were also compared by examining the confidence intervals developed from the separate univariate ANOVA for each treatment.

Two-to-one Lane Configuration

For this configuration, one-way ANOVA showed no statistically significant difference between throughput values for the MUTCD and late merge. The results are shown in Tables 28 and 29.

Although a numerical increase in throughput was shown, the late merge did not provide a statistically significant improvement across all scenarios when compared to the MUTCD treatment for a 2-to-1-lane closure. Figures 6 through 8, created from the univariate ANOVA data, present an overview of how the late merge compared to the MUTCD treatment for the 2-to-1-lane closure scenario. A graph is shown for each factor, demonstrating how it influenced throughput. In Figure 6, it is clear that throughput is higher for the late merge for both free flow speeds in the 2-to-1 configuration, although practically speaking, the difference was small.

Figure 7 shows that throughput was lower with the late merge when the percentage of heavy vehicles was small; however, late merge throughput steadily increased and surpassed that of the MUTCD control; as the percentage of heavy vehicles increased. This trend was consistent across demand volumes of 1,000 vphpl and higher.

Table 28. Late Merge vs. MUTCD Throughput Descriptive Statistics for 2-to-1 Lane Configuration

Treatment	N	Mean Throughput (vph)	Std. Deviation	95% Confidence Interval for Mean		Minimum (vph)	Maximum (vph)
				Lower Bound (vph)	Upper Bound (vph)		
MUTCD	960	1269.22	160.99	1259.03	1279.42	967	1479
Late Merge	960	1274.47	163.62	1264.11	1284.84	944	1463
Total	1920	1271.85	162.29	1264.58	1279.11	944	1479

Table 29. Late Merge vs. MUTCD Throughput ANOVA for 2-to-1 Lane Configuration

Source	Sum of Squares	df	Mean Square	F	Sig.
Between Groups	13224.75	1	13224.75	0.50	0.48
Within Groups	50529136.14	1918	26344.70		
Total	50542360.9	1919			

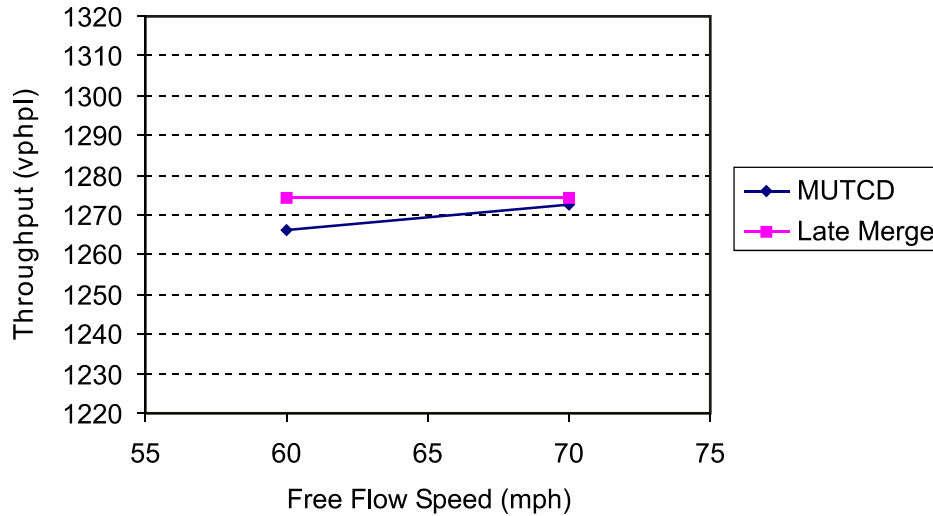

Figure 6. Throughput vs. Free Flow Speed for 2-to-1 Closure

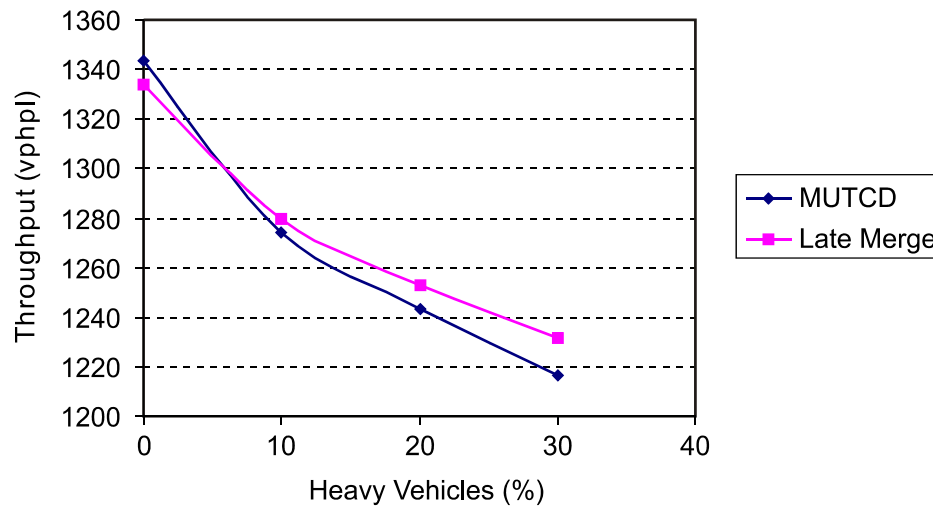

Figure 7. Throughput vs. Percent Heavy Vehicles for 2-to-1 Closure

In Figure 8, throughput values for the MUTCD and late merge control are close at all volumes. However, when broken out by percentage of heavy vehicles, it is clear that as more heavy vehicles enter the system, the late merge has an increased advantage at moving the vehicles through the lane closure. As the percentage of heavy vehicles increases, large gaps in traffic open up in front of the heavy vehicles because of their lower acceleration performance. With the late merge, these gaps are filled by advancing traffic, which results in better usage of available capacity. The exact relationship between throughput and demand volume is unknown, however, between volumes of 500 and 1,000 vphpl.

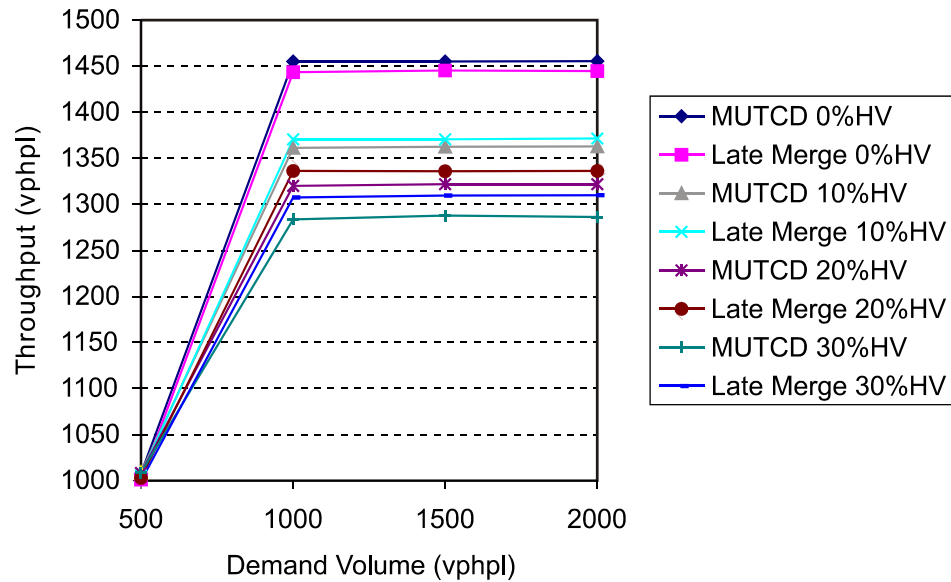

Figure 8. Throughput vs. Demand Volume for 2-to-1 Closure

Three-to-one Lane Configuration

For the 3-to-1 configuration, one-way ANOVA showed a statistically significant difference between throughput values for the MUTCD and late merge control. The results are shown in Tables 30 and 31.

Table 30. Late Merge vs. MUTCD Throughput Descriptive Statistics for 3-to-1 Lane Configuration

Treatment	N	Mean Throughput (vph)	Std. Deviation	95% Confidence Interval for Mean		Minimum (vph)	Maximum (vph)
				Lower Bound (vph)	Upper Bound (vph)		
MUTCD	960	1153.76	145.09	1144.57	1162.95	917	1436
Late Merge	960	1285.05	170.00	1274.28	1295.82	923	1481
Total	1920	1219.40	171.10	1211.75	1227.06	917	1481

Table 31. Late Merge vs. MUTCD Throughput ANOVA for 3-to-1 Lane Configuration

Source	Sum of Squares	df	Mean Square	F	Sig.
Between Groups	8274526.01	1	8274526.0	331.31	0
Within Groups	47901968.36	1918	24974.96		
Total	56176494.47	1919			

When comparing the coefficients from the univariate ANOVA, in all scenarios, the late merge produces higher throughput volumes than the MUTCD treatment by a statistically significant margin. Figures 9 through 11 present an overview of how the late merge compared to the MUTCD treatment for the 3-to-1-lane closure scenario. It is clear in Figure 9 that the late merge had a significant impact on throughput at both free flow speeds, with a 120 to 130 vphpl increase over the MUTCD.

Figure 10 shows that the late merge is superior at various percentages of heavy vehicles. However, the difference between the two types of traffic control decreased as the percentage of heavy vehicles increased.

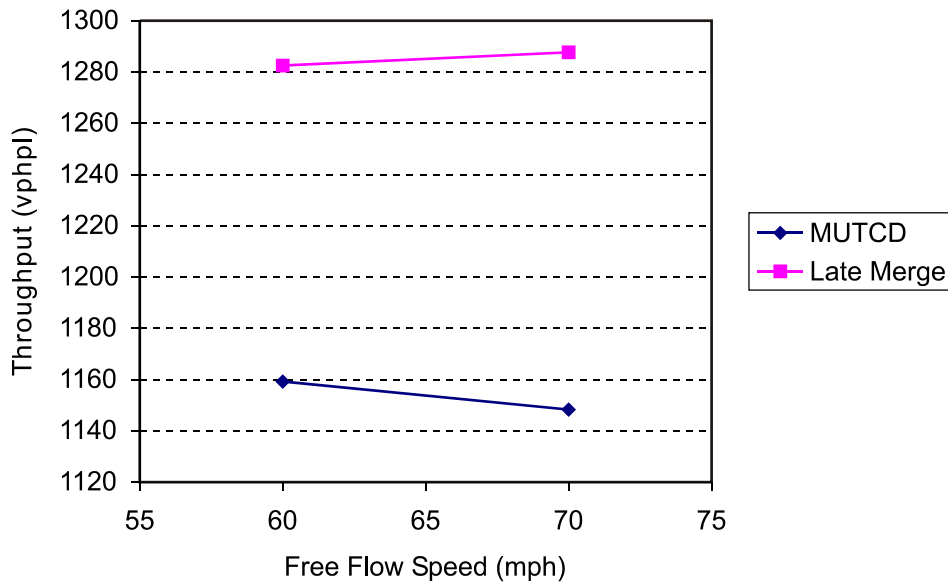

Figure 9. Throughput vs. Free Flow Speed for 3-to-1 Closure

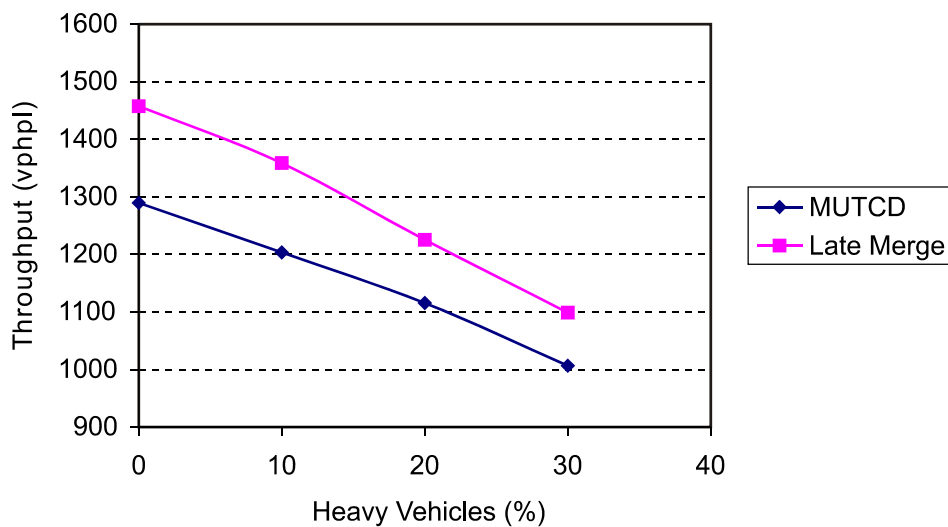

Figure 10. Throughput vs. Percent Heavy Vehicles for 3-to-1 Closure

In Figure 11, throughput is higher at all volume levels for the late merge and rather consistent as compared to the MUTCD treatment.

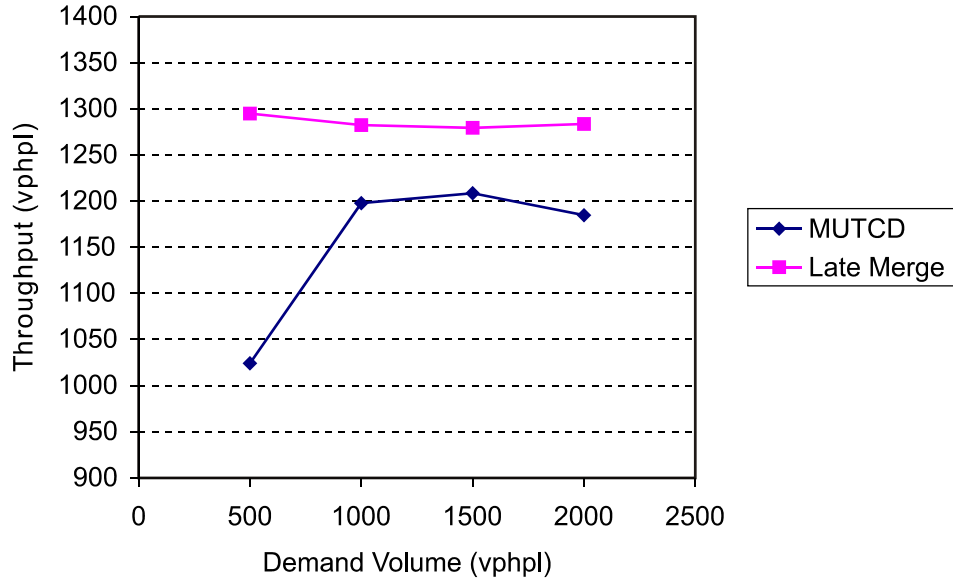

Figure 11. Throughput vs. Demand Volume for 3-to-1 Closure

Three-to-two Lane Configuration

For this configuration, one-way ANOVA showed no statistically significant difference between throughput values for the MUTCD and late merge control. The results are shown in Tables 32 and 33.

Table 32. Late Merge vs. MUTCD Throughput Descriptive Statistics for 3-to-2 Lane Configuration

Treatment	N	Mean Throughput (vph)	Std. Deviation	95% Confidence Interval for Mean		Minimum (vph)	Maximum (vph)
				Lower Bound (vph)	Upper Bound (vph)		
MUTCD	960	2304.28	476.00	2274.13	2334.42	1456	2808
Late Merge	960	2278.94	454.17	2250.17	2307.70	1454	2681
Total	1920	2291.61	465.26	2270.78	2312.43	1454	2808

Table 33. Late Merge vs. MUTCD Throughput ANOVA for 3-to-2 Lane Configuration

Source	Sum of Squares	df	Mean Square	F	Sig.
Between Groups	308104.00	1	308104.00	1.42	0.23
Within Groups	415093879.9	1918	216420.17		
Total	415401983.9	1919			

From these results, it is clear that the 3-to-2-lane configuration did not lend itself well to the late merge concept. Even the 2-to-1 configuration showed at least a numerical improvement in throughput with the late merge overall (although statistically insignificant). A possible explanation may be evident in the way vehicles appeared to be behaving in the simulations. When simulation animations of the 3-to-2 lane configuration of the late merge control were viewed, it appeared that vehicles driving in the middle lane would move to the far left lane to avoid merging vehicles from the closing lane. This interaction slowed vehicles in the far left lane enough that throughput may have been significantly reduced. A screenshot of this phenomenon is included in Figure 12.

Although the overall comparison showed no significant difference in throughput, there was at least one situation where the late merge did show promise. As with the 2-to-1 configuration, at demand volumes above 1,000 vphpl, the late merge outperformed the MUTCD treatment when the percentage of heavy vehicles was high (>20 percent). Figures 13 through 15 present an overview of how the late merge compared to the MUTCD treatment for the 3-to-2 lane closure scenario. In Figure 13, the MUTCD is shown to be superior at both free flow speeds, although practically speaking, the difference was small at 12 to 15 vphpl.

Figure 14 shows that only at heavy vehicle percentages of 20 percent and above does the late merge outperform the MUTCD treatment in the 3-to-2 configuration. This trend was consistent across demand volumes of 1,000 vphpl and higher.

Similar to results from the 2-to-1 configuration, 3-to-2 throughput values for the late merge and MUTCD treatment were very close for different demand volumes as shown in Figure 15. Again though, the late merge shows an increased advantage in throughput as the percentage of heavy vehicles is increased. However, the exact relationship between throughput and demand volume between volumes of 500 and 1,000 vphpl is unknown.

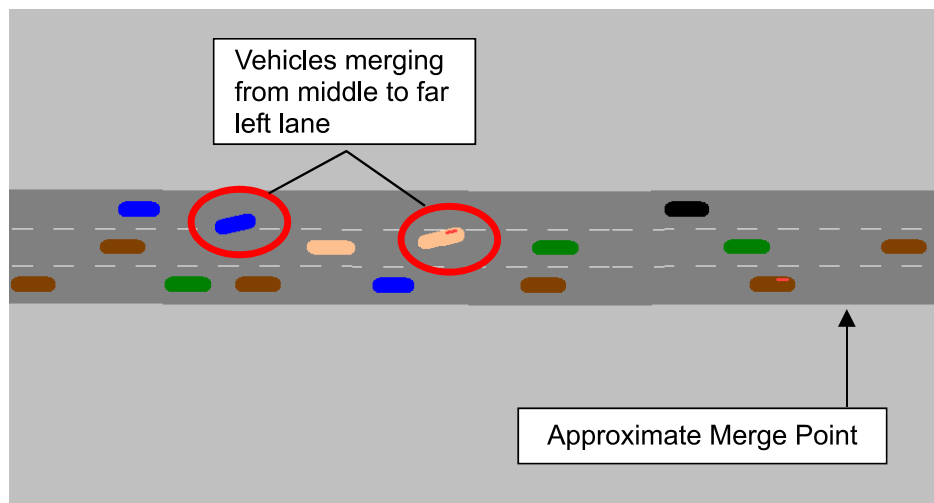

Figure 12. VISSIM Screenshot of 3-to-2 Configuration Late Merge Behavior

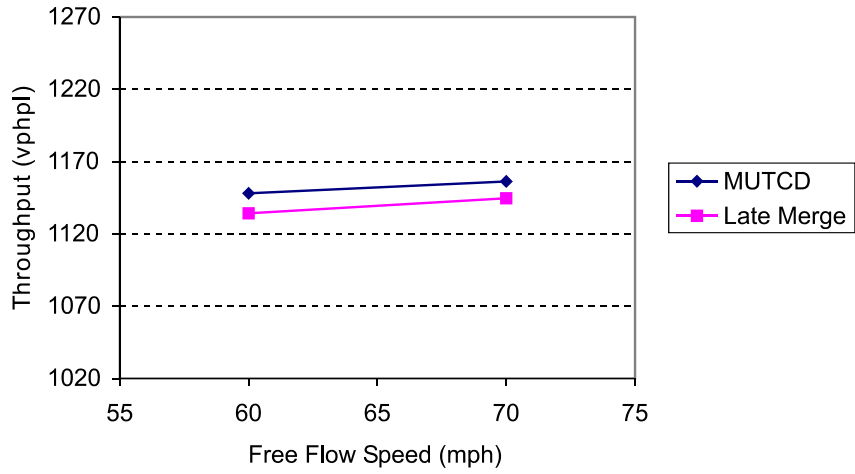

Figure 13. Throughput vs. Free Flow Speed for 3-to-2 Closure

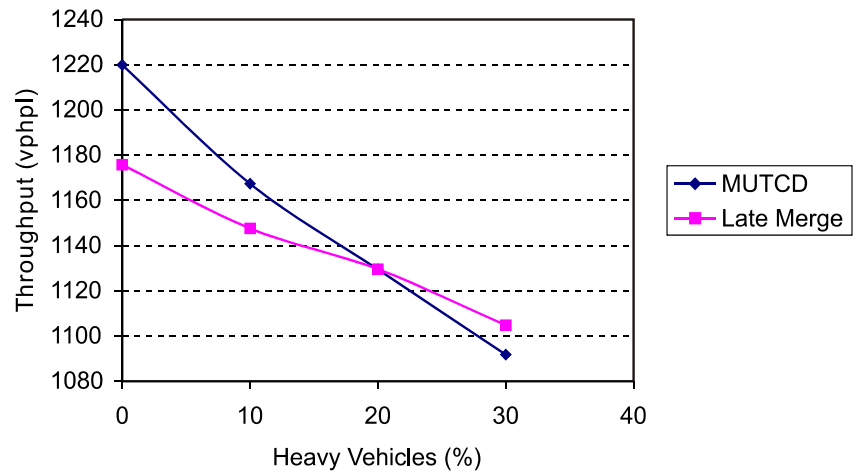

Figure 14. Throughput vs. Percent Heavy Vehicles for 3-to-2 Closure

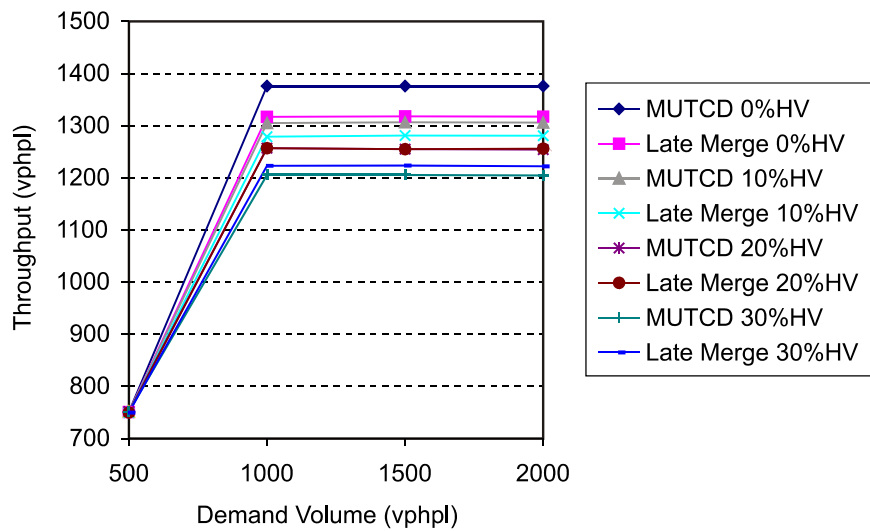

Figure 15. Throughput vs. Demand Volume for 3-to-2 Closure

Cost Comparison

Table 34 summarizes the road user costs savings created by using the late merge that were generated using QUEWZ-92. Cases where the costs savings are negative indicate that the traditional MUTCD merge provides lower delays and user costs than the late merge. In some instances, the simulations indicate that the late merge would not have a benefit. The results of the simulations were used to generate these cost savings, and benefits of the late merge could be mitigated if lower compliance rates with traffic control were observed.

All three lane closure scenarios had regions where it appeared the late merge would provide a benefit to drivers. The 3-to-1 closure provided benefits for all combinations of variables, and the 2-to-1 and 3-to-2 closures indicated that the late merge would be beneficial when the percentage of heavy vehicles crossed a particular threshold. It is unlikely that there are many instances where a 1,500 or 2,000 vphpl demand volume would be maintained for an entire 8-hour period. These demand volumes are provided for the sake of comparison.

Table 34. Late Merge vs. MUTCD Road User Cost Savings per 8 Hours (2004 Dollars)^a

Lane Closure Configuration	% Heavy Vehicles	Demand Volume per Hour (vphpl)			
		500	1000	1500	2000
2 to 1	1	-\$26	-\$7,986	-\$11,224	-\$14,515
	10	\$17	\$4,455	\$6,236	\$8,041
	20	\$52	\$10,963	\$15,274	\$19,637
	30	\$103	\$17,649	\$24,498	\$31,422
3 to 1	1	\$103,825	\$157,167	\$212,462	\$268,661
	10	\$106,296	\$156,648	\$216,372	\$273,310
	20	\$84,200	\$126,265	\$170,171	\$214,642
	30	\$76,717	\$114,649	\$154,350	\$331,451
3 to 2	1	-\$180	-\$117,480	-\$173,083	-\$229,547
	10	-\$125	-\$72,978	-\$106,638	-\$140,751
	20	\$0	\$0	\$0	\$0
	30	\$10	\$49,497	\$71,363	\$93,450

^aValues represent (MUTCD road user costs) – (Late merge road user costs).

Summary of Simulation Results

Factors Influencing the MUTCD Treatment

- Lane configuration had a significant influence on performance. Throughput was highest for the 3-to-2 configuration, followed by the 2-to-1 and then the 3-to-1 configurations.
- Percentage of heavy vehicles influenced performance. As the percentage was increased from 0 to 30 percent, throughput dropped by approximately 13 percent.
- Demand volume had a statistically significant influence only up to 1,000 vphpl, after which throughput remained nearly constant (the system had reached capacity).

Factors Influencing the Late Merge Treatment

- As with the MUTCD treatment, lane configuration had a significant influence on performance. Throughput was higher in the 3-to-1 configuration than in the 2-to-1 configuration.
- As with the MUTCD treatment, as the percentage of heavy vehicles was increased, throughput was reduced significantly. However, as the percentage was increased from 0 to 30 percent, the reduction was only 11 percent.
- As with the MUTCD treatment, demand volume had a statistically significant influence only up to 1,000 vphpl, where the system reached capacity.

Comparison of Treatments

- Throughput appeared to be higher with the late merge for the following conditions: higher percentages of heavy vehicles, for both free flow speeds of 60 and 70 mph (primarily from 2-to-1 and 3-to-1 scenarios), and in all cases of the 3-to-1 lane configuration.
- Overall, throughput for the late merge and the MUTCD treatments was not significantly different for the 2-to-1 and 3-to-2 lane configurations.

Cost Comparison

- There are potential road-user cost benefits to using the late merge. Benefits were most pronounced with high percentages of heavy vehicles. The late merge appeared to be most effective in the 3-to-1 and 2-to-1 lane closure scenarios.

Site Selection and Description

Seven sites in Virginia were proposed for evaluation. Only two met the criteria for field-testing as described in the methodology. Figure 16 shows the location of the sites. The Tappahannock site was in VDOT's Fredericksburg District, and the Eltham site was in the Richmond District.

Although the sites did show potential for the required congestion characteristics, they were not optimal. Neither site was on an access-controlled highway as originally desired; they were on Virginia primary and U.S. routes with access points on the approaches to the work zone. Both sites had traffic signals within the queuing area, presenting opportunities for disturbance to traffic flow. These characteristics also made it more difficult to correlate findings with those of the simulations (since the simulations were modeled after freeways). Last, the site in Eltham was not a work zone lane closure, but rather a lane reduction because of a two-lane bridge. This drawback was somewhat lessened by the fact that local VDOT crews installed a temporary lane closure during periods of congestion. The closure was installed in advance of the existing lane

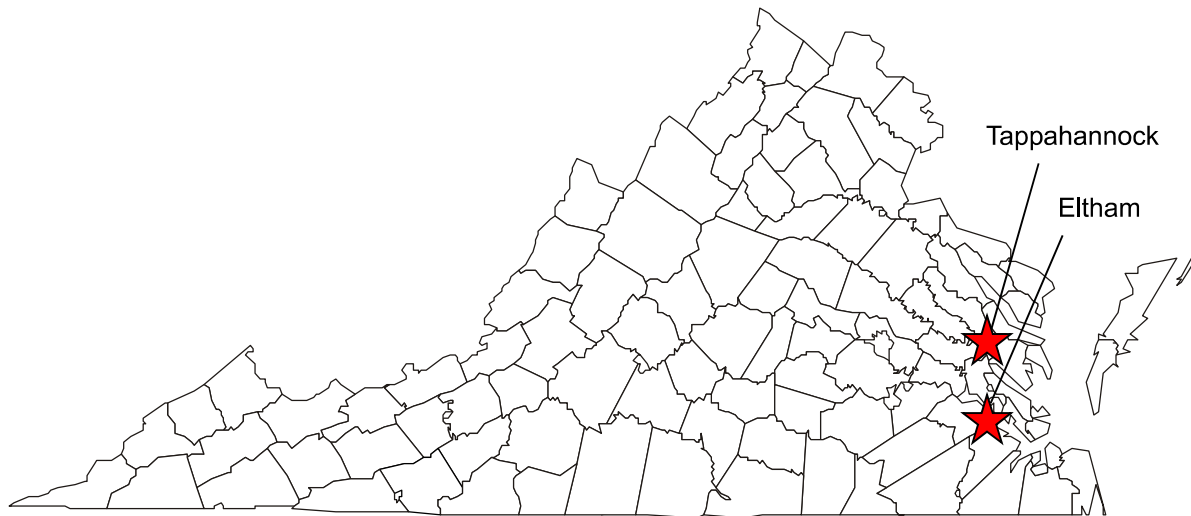

Figure 16. Site Locations in Virginia

drop in an attempt to provide better advance warning of the lane reduction and thus prompt a smoother merging operation.

Despite these drawbacks, it was felt that field tests at these locations would provide valuable information as to the efficacy of the late merge and that the results could be used for comparison with the simulations.

Tappahannock

The Tappahannock site was at a work zone lane closure roughly 0.5 mile south of the city's downtown area. Route 17/360 is a four-lane divided arterial with an annual average daily traffic (AADT) of 21,863 in 2003. The percentage of heavy vehicles was about 6.4. Figure 17 is a sketch of the site including cross streets and existing traffic control. The traffic control was similar to that in Chapter 6H of the VAWAPM.²

The site typically had congestion during the peak hour on Thursday and Friday. Much of the congestion was due to seasonal traffic to access the Rappahannock River. Under congested conditions, 15-minute volume counts varied between 250 and 275 vehicles through the work zone. The speed limit approaching the work zone was 45 mph and was reduced to 35 mph approximately 200 feet prior to the arrow panel. The speed limit was again reduced to 25 mph at 1,000 feet after the taper. The study area included three traffic lights and additional access points and crossovers throughout the area. The mainline ratio of green time to traffic signal cycle length (g/C) and cycle lengths are provided in Table 35. The g/C ratio for a signal refers to the ratio of effective green time to cycle length for the direction of interest.

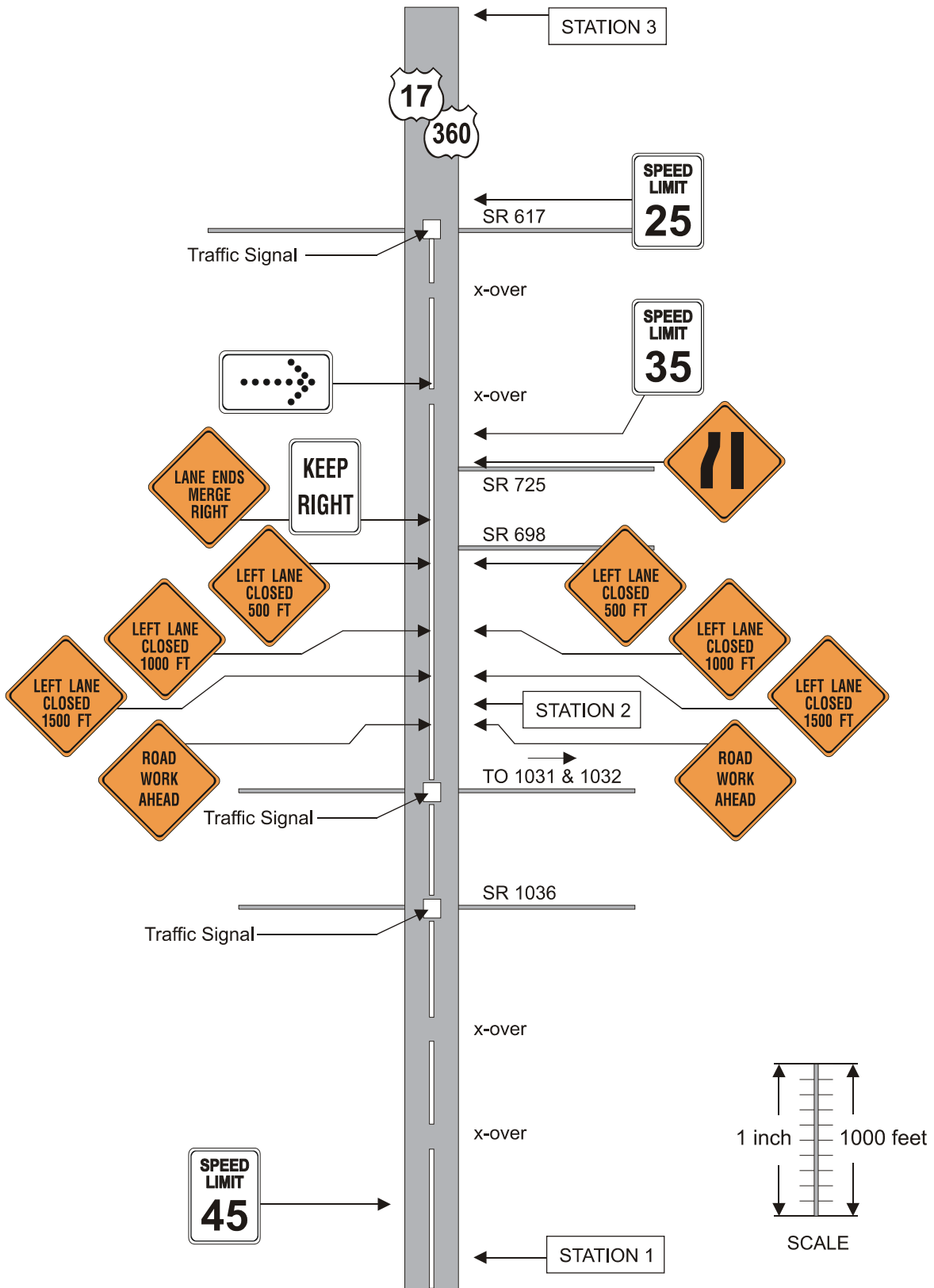

Figure 17. Tappahannock Site Diagram with Existing MUTCD Traffic Control

Table 35. Tappahannock Traffic Signal Settings

Traffic Signal	Mean Cycle Length (sec)	Mean g/C Ratio
Intersection with SR 1036	92	0.43
Intersection with SR 1031/1032	99	0.45
Intersection with SR 617	111	0.72

The traffic signals, lane closure, and a typical queue are shown in Figures 18, 19, and 20, respectively.



Figure 18. Tappahannock Traffic Signals



Figure 19. Tappahannock Lane Closure



Figure 20. Tappahannock Traffic Queue

Eltham

The site at Eltham was at a lane drop along State Route 33 heading eastbound toward West Point. In the area of the study, Route 33 transitions from a four-lane highway with a median to a four-lane undivided arterial. It had an AADT of 14,851 in 2003 with approximately 11 percent trucks. The site was a lane drop on the approach to a two-lane bridge. But, as noted earlier, VDOT workers installed a temporary lane closure during congested conditions to prompt earlier and smoother merging.

Congestion did not occur on a recurring basis. When congestion did occur, it was usually on a Friday. During these periods, the 15-minute volume counts varied between 200 and 275 vehicles through the work zone. The speed limit approaching the work zone was 45 mph and was reduced to 35 mph after the lane drop.

The study period for Eltham was from July 17 to September 8, 2003. Volume and queue data were collected for both treatments. The size of the data sets for each treatment was limited primarily by a lack of congestion at the site. Only 2 days of queue data were collected with the MUTCD treatment in place and only 1 day with the late merge in place. Due to this lack of data, it was impossible to generate any statistically meaningful conclusions about the performance of the late merge at the site. As a result, these results are not discussed in this report. Readers desiring information on the details of this deployment are invited to consult the work by Beacher.²⁰

Data Collection and Site-Specific Adjustments

The study period for Tappahannock was from July 9 to September 26, 2003. Volume and queue data were collected for both treatments, beginning with the MUTCD treatment. The size of the data sets for each treatment was limited by occasional counter failures and periods of limited congestion.

MUTCD Data

MUTCD volume data were collected from July 9 through August 12 from the counters and loop detectors in place at stations 1, 2, and 3. Six days of queue data were collected by the probe vehicles. The traffic control was as described in the site description.

Late Merge Data

The late merge traffic control signs were installed on August 13 and placed in accordance with to the site sketch in Figure 21. Photographs of the signs are shown in Figures 22 and 23. Relevant MUTCD traffic control was left in place, and the LANE ENDS MERGE RIGHT and KEEP RIGHT signs were covered to avoid providing information to motorists that contradicted the late merge sign instructions. Late merge volume data were collected August 13 to September 26. Seven days of queue data were collected with the late merge treatment in place.

Site-Specific Adjustments

In Tappahannock, where congestion was frequent and at times unpredictable, VDOT inspectors recommended that the late merge signs be left up at all times to maintain a level of consistency in what the local motorists were encountering and thus ensure adequate safety.

Field Test Results

General Observations

General observations were made regarding the performance of the late merge during data collection. At Tappahannock, it appeared that on the whole, turn-taking behavior was not adopted as readily by motorists as had been hoped. Further, lane straddling was still prevalent, especially by trucks. This may have occurred for several reasons:

- habitual driving (since work zones had been in place with MUTCD treatment for an extended period prior to the late merge)
- motorists' lack of familiarity with the system (it had never been tested in Virginia)
- numerous access points and distractions along the route, creating the possibility that motorists missed the first set of late merge signs or simply forgot the instructions.

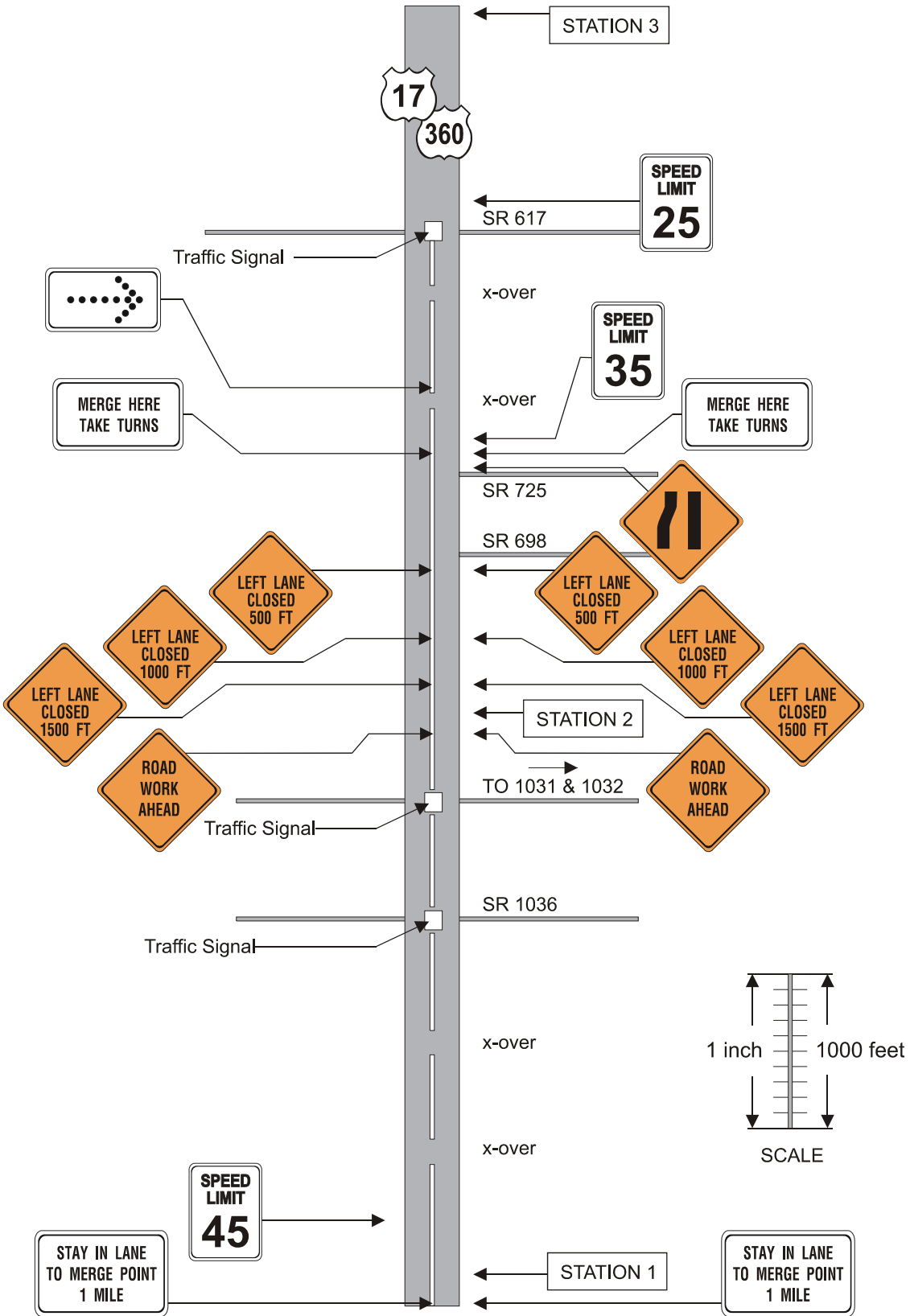

Figure 21. Tappahannock Site Diagram with Late Merge Traffic Control



Figure 22. STAY IN LANE TO MERGE POINT 1 MILE Signs, Tappahannock



Figure 23. MERGE HERE TAKE TURNS Signs, Tappahannock

Table 36. Descriptive Statistics: Percentage of Vehicles in the Closed Lane, Late Merge vs. MUTCD, Tappahannock

Treatment	N	Mean (%)	Std. Deviation	95% Confidence Interval for Mean		Minimum (%)	Maximum (%)
				Lower Bound (%)	Upper Bound (%)		
MUTCD	34	33.66	8.59	30.66	36.66	22.86	50.86
Late Merge	100	38.81	8.64	37.10	40.53	23.46	57.22
Total	134	37.50	8.88	35.99	39.02	22.86	57.22

Table 37. ANOVA: Percentage of Vehicles in the Closed Lane, Late Merge vs. MUTCD, Tappahannock

Source	Sum of Squares	df	Mean Square	F	Sig.
Between Groups	673.20	1	673.20	9.04	0.00
Within Groups	9825.25	132	74.43		
Total	10498.45	133			

Throughput

One-way ANOVA showed no statistically significant difference between throughput for the MUTCD and late merge, although a small increase in mean throughput occurred. Since there was no statistically significant difference, it does not appear that the late merge improved throughput relative to the MUTCD control. Although the simulations were based on freeway conditions, they might provide insight into why this was the case. Tappahannock had approximately 6.4 percent heavy vehicles. From the simulation study, throughput for the 2-to-1-lane closure did not increase with the late merge in place until the percentage of heavy vehicles reached at least 20 percent, likely due to the acceleration characteristics of trucks. Having large numbers of slow trucks tends to result in large gaps that can either slow the queue progression in the case of the MUTCD treatment or provide opportunities to maximize storage space in the case of the late merge. Tappahannock may not have had the conditions favorable for the late merge. The results are shown in Tables 38 and 39.

Table 38. Descriptive Statistics: Throughput, Late Merge vs. MUTCD, Tappahannock

Treatment	N	Mean (vph)	Std. Deviation	95% Confidence Interval for Mean		Minimum (vph)	Maximum (vph)
				Lower Bound (vph)	Upper Bound (vph)		
MUTCD	34	255.74	14.82	250.57	260.91	205	273
Late Merge	100	258	19.86	254.06	261.94	213	291
Total	134	257.43	18.68	254.23	260.62	205	291

Table 39. ANOVA: Throughput, Late Merge vs. MUTCD, Tappahannock

Source	Sum of Squares	df	Mean Square	F	Sig.
Between Groups	130.14	1	130.14	0.37	0.54
Within Groups	46274.62	132	350.57		
Total	46404.75	133			

Time in Queue

Separate regression models were developed to predict the time in queue for the MUTCD and late merge traffic control. Both models were created using stepwise regression, and both took a similar form. The model for time in queue for the MUTCD was:

$$\text{Time in queue (sec)} = -15.468 + 6.559 \times 10^{-5} \text{QL}^2 + 1.181 \text{PCL}$$

where

QL = queue length in open lane (ft)

PCL = percentage of traffic in closed lane

This model was built using 66 data points, each of which represented a separate travel time run. The equation has an R^2 of 0.96. The coefficient for queue length had a significance of 0.000, and the coefficient for percentage of traffic in the closed lane had a significance of 0.066. Figure 24 shows the relationship between queue length and time in queue for the MUTCD traffic control. Variations in the model line are the result of the influence of the PCL variable.

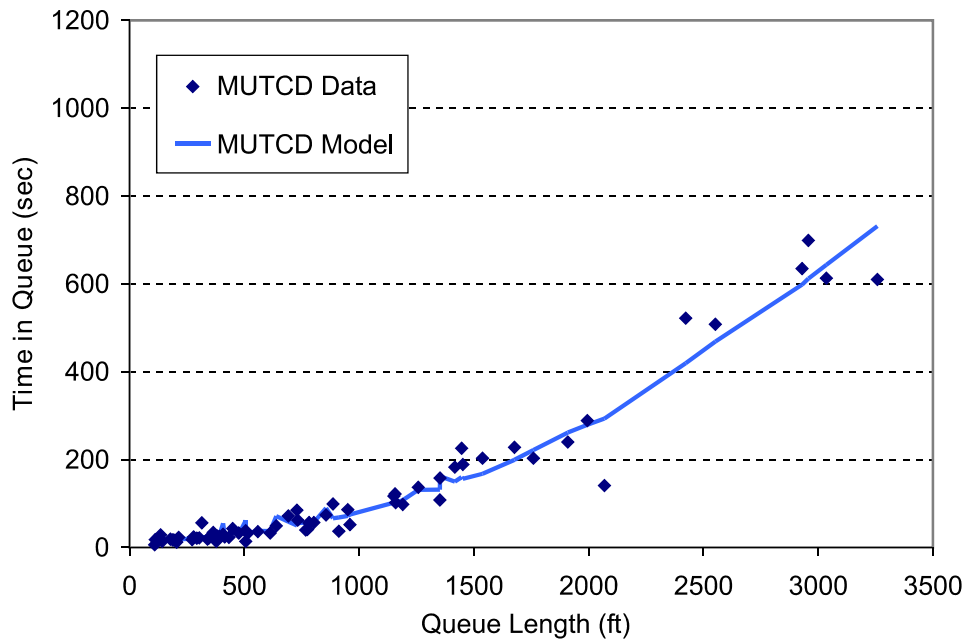

Figure 24. Time in Queue for MUTCD Control

Another model was constructed to describe time in queue for the late merge traffic control. The model for the late merge took the form:

$$\text{Time in queue (sec)} = -67.918 + 6.258 \times 10^{-5}QL^2 + 2.630PCL$$

This model was constructed using 121 data points and had an R^2 of 0.86. The coefficient for queue length had a significance of 0.000, and the coefficient for percentage of traffic in the closed lane had a significance of 0.013. Figure 25 shows the relationship between queue length and time in queue, with variations in the model line caused by the PCL variable.

Comparison of the models for the late merge and MUTCD traffic control revealed several trends. It should be noted that the confidence intervals for the coefficients in the time in queue models overlap; therefore, there is not a statistically significant difference between the two models. In addition, these models are applicable only to the conditions seen at the Tappahannock site and cannot necessarily be transferred to other locations.

Even though the models are not statistically different, some trends are apparent in the model. The late merge appears to perform better with respect to MUTCD traffic control as queue lengths increase. That is, drivers tend to see more tangible travel time reductions at longer queues. Although the percentage of vehicles in the closed lane factor is included in both models, it becomes less and less significant as queue lengths increase. These results appear to be intuitive, since increasing queue lengths are representative of significant congestion, thereby increasing the need for vehicles to fill in gaps in front of heavy vehicles.

Figure 26 is a graph of the relative benefit of using the late merge versus MUTCD traffic control at Tappahannock. The travel timesavings were computed by subtracting the predicted

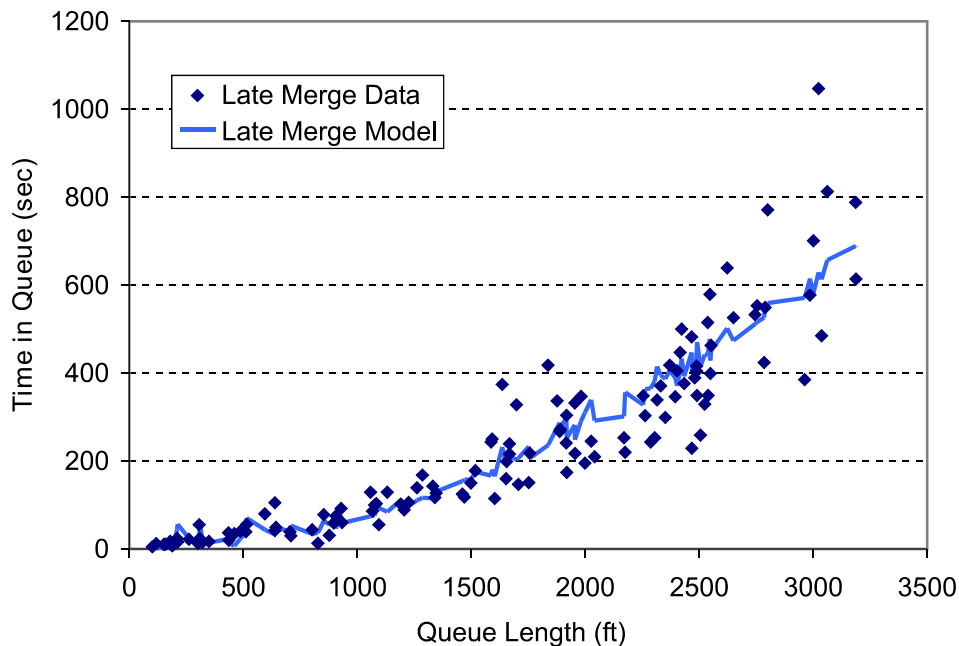

Figure 25. Time in queue for Late Merge Control

MUTCD travel time from the predicted late merge travel time. The savings in travel time were calculated by using the developed models. The percentage of vehicles in the closed lane was set to a constant value equal to the observed means for each type of traffic control. In the Tappahannock case, these were 33.7 percent for MUTCD control and 38.8 percent for the late merge. Queue lengths were then varied to generate the curve shown.

Observation of Figure 26 shows that the MUTCD control is predicted to work well when queue lengths are short. When queue lengths exceeded approximately 1,800 feet, the late merge began to provide travel timesavings over the MUTCD control. Although some benefits do appear to occur, the travel timesavings are small, on the order of an improvement of 3 percent, when queue lengths exceed 3,000 feet.

Again, the gaps that open up in front of large vehicles may provide a physical explanation for this phenomenon. The late merge was expected to improve traffic operations through two means: (1) encouraging more orderly merging at the taper, thereby reducing turbulence in the traffic stream and (2) creating opportunities for drivers in the closed lane to fill in gaps in front of large trucks created by their relatively poor performance characteristics. The queue length would likely need to exceed a particular point before the benefits of the second explanation would come into play, and this may be what is seen in Figure 26.

Regression equations were also developed to attempt to explain a relationship between the maximum queue length and existing demand at the site. No realistic models could be developed to predict maximum queue length, so this was abandoned. The inability to determine an accurate model for maximum queue length was likely due to the influence of intermediate access points in the work zone advance warning area at Tappahannock.

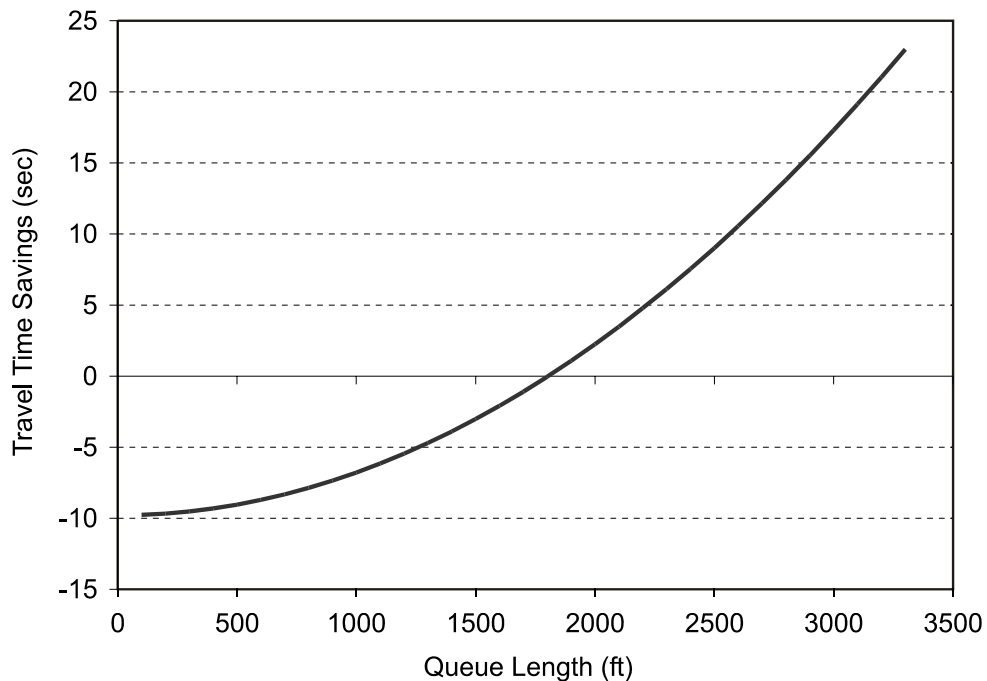

Figure 26. Per Vehicle Travel Time Savings (MUTCD – Late merge predicted time in queue).

Crash Statistics

The crash data during the study period were examined for the Tappahannock site. From VDOT's HTRIS database it was discovered that during the study period, two crashes occurred in the work zone advance warning area while the MUTCD treatment was in place (35 days). Two crashes occurred while the late merge was in place (51 days). In both cases, the crashes consisted of one rear-end collision and one angle collision. Based on these limited data, there is no apparent difference between data from before and after late merge implementation.

Given the purported safety merits of the late merge, a more extensive safety analysis consisting of an examination of merging conflicts was desired. However because of personnel limitations, it was simply not possible. Recommendations for further study on this topic are provided at the end of this report.

Field Test Summary

- The percentage of vehicles in the closed lane showed a statistically significant increase from 33.7 to 38.8 percent when comparing the late merge to the MUTCD treatment.
- Throughput volumes showed no statistical difference between the MUTCD treatment and the late merge.
- Time in queue was not significantly different between the two types of traffic control. The models show some benefit for the late merge when queues are long. The lack of improvement in throughput and time in queue may be attributable to the relatively low percentage of heavy vehicles at the site.

Field Test Limitations

Several limitations of the sites may have inhibited greater success with the late merge in the field:

- Lack of work zones on freeways in Virginia limited the choice of test sites to two primary routes.
- The Eltham site did not have significant recurring congestion, so no statistically meaningful data could be collected at that site.
- Traffic signals in the advance warning areas of both sites and just after the work zones affected queue generation.
- There were multiple access points along the advance warning areas of the test sites.
- Both work zones and lane drops were in place for a long period of time prior to introduction of late merge.

- The percentage of trucks was relatively low at the sites.

CONCLUSIONS

Frequently, comparisons were made and parallels drawn between the simulations and field studies with full knowledge that the simulations were modeled after freeways and the field studies were conducted on primary arterials. It is believed that the data support these comparisons, despite obvious inherent differences, including accessibility and the presence of traffic signals.

Simulations

Lane Configuration

- *Lane configuration had a significant impact on throughput.* When corresponding treatment throughput values were compared for each configuration, it became obvious which configuration experienced more of a benefit using the late merge over the MUTCD merge. The 3-to-1-lane configuration had an overall average improvement in throughput of 132 vph. The 2-to-1 and 3-to-2 configurations had either limited or statistically insignificant improvements. This is likely because the 3-to-1 configuration represents such a dramatic loss of capacity, and therefore the late merge becomes very important since it makes the most use of the available capacity prior to the lane reductions.

Percentage of Heavy Vehicles

- *The percentage of heavy vehicles had a strong relationship with throughput, and the late merge became more efficient than the MUTCD treatment as the percentage of heavy vehicles was increased.* It is believed that this was the case of poor acceleration characteristics of trucks, which tend to result in large gaps between trucks and the vehicles in front of them. Increased numbers of gaps slow the queue progression with the MUTCD treatment. With the late merge, cars are free to fill the gaps, which results in better use of available capacity. The only exception to this was the 3-to-1 configuration, where the throughput was improved by a statistically significant margin for all percentages of heavy vehicles.

Cost Comparison

- *Road-user cost savings mirror the potential throughput improvements created by the late merge.* There are potential road-user cost benefits to using the late merge. Benefits were most pronounced with high percentages of heavy vehicles. The late merge appeared to be most effective in the 3-to-1 and 2-to-1 lane closure scenarios.

Field Tests

Throughput

- *Analysis of the Tappahannock data showed that throughput was not improved by a statistically significant margin using the late merge.* This result may be explained by the fact that Tappahannock had approximately 6.4 percent heavy vehicles. The results of the simulation study indicated that throughput would not increase with the late merge unless the percentage of heavy vehicles was at least 10 percent for a 2-to-1-lane closure.

Percentage of Vehicles in the Closed Lane

- *Data from Tappahannock showed that the percentage of vehicles in the closed lane increased by 5.1 percent when the late merge was in place.* This demonstrates that drivers were responding to the late merge signs as expected. It also demonstrates that even though increased throughput may not be attainable at relatively low truck percentages, other benefits can be achieved.

Time in Queue

- *The Tappahannock data showed that the late merge produced small improvements in time in queue when queues were long.* This suggests that a minimum level congestion, as represented by a minimum queue length, is required before the late merge produces appreciable improvements over MUTCD control. As discussed earlier, the percentage of heavy vehicle appears to be a strong determinant as to whether the late merge will offer operational improvements at a site. Since the Tappahannock site had a relatively low percentage of trucks, the time in queue differences between the two forms of traffic control were not statistically significant.

PROPOSED GUIDELINES FOR APPLICATION

Even though the results of the field tests and the simulations were not directly comparable, they seem to suggest that the percentage of heavy vehicles in the traffic stream plays an important role in the efficacy of the late merge. As a result, the proposed guidelines for application of the late merge focus on the percentage of heavy vehicles.

- *Two-to-one configuration.* The late merge should be considered for 2-to-1 lane closure configurations to improve throughput when large numbers of heavy vehicles are present (>20 percent) for the majority of the time and congestion and queuing are often present.
- *Three-to-one configuration.* While the simulation results showed that the late merge significantly improved throughput for all situations, there are no documented evaluations of the deployment of the late merge in this configuration. Further research is needed to determine how the late merge could be deployed in this type of configuration to ensure driver understanding of the signs.

- *Three-to-two configuration.* The late merge should be considered in the 3-to-2 configuration as a possible means to improve flow when heavy vehicles represent more than 20 percent of the traffic stream and congestion and queuing are frequent. Again, however, the concept should be field tested at site with these characteristics to ensure they are realistically attainable.

RECOMMENDATION

Although the results of this project indicate that the late merge has promise, more research needs to be done before it is implemented on a widespread basis.

Items that require investigation include:

- The 2-to-1-lane configuration should be tested on a freeway to examine the late merge in a more controlled environment (thus avoiding traffic signals and access points). This site should have at least 20 percent heavy vehicles.
- A methodology for deployment (including proposed text for signs) of the 3-to-1 configuration should be developed and a field test should be conducted to validate the results shown in the simulations.
- Drivers should be surveyed to determine the most effective wording for the late merge signs (STAY IN LANE versus USE BOTH LANES). This could be accomplished by surveying drivers for their understanding/preference of the selected messages and then following up with field tests.
- Changeable message signs should be deployed at all test sites to reinforce the late merge concept, especially those sites where the MUTCD treatment has been in place for several months or more. The signs would reiterate that motorists may use all of the travel lanes up to the merge point. This is necessary since motorists seemed to be reluctant to change merging habits and/or entered the system after initial late merge signs were displayed and thus were not aware of the new traffic control.
- Ideally, the late merge should be tested starting at the time of work zone deployment so that drivers are not already “set in their ways” using the standard MUTCD merging process at that particular location.
- The safety aspect of the late merge should be further explored to determine whether it does in fact reduce conflicts and crashes (particularly sideswipes and rear-end collisions). Video cameras should be used in these tests. The effect of the late merge on speeds should also be determined.
- The late merge should be tested in a dynamic format so that the merits of a congestion-responsive system can be discerned.

ACKNOWLEDGMENTS

A number of people contributed to the completion of this project. Lewis Woodson provided invaluable technical assistance in the field data collection phase, and Daryl Thomas aided in the field data collection. David Rush aided in the site selection phase, and Travis Bridewell and Jeff Hores provided assistance in coordinating the fabrication and placement of the late merge signs in the field. The project advisory panel also provided valuable insight into the deployment of the late merge.

REFERENCES

1. Federal Highway Administration. *Manual on Uniform Traffic Control Devices*. Washington, D.C., 2003.
2. Virginia Department of Transportation. *Virginia Work Area Protection Manual: Standards and Guidelines*. Richmond, 2003.
3. Walters, C.H., and S.A. Cooner. *Understanding Road Rage: Evaluation of Promising Mitigation Measures*. Report 4945-2. Texas Transportation Institute, College Station, 2001.
4. Bernhardt, K.L.S., M.R. Virkler, and N.M. Shaik. Evaluation of Supplementary Traffic Control Measures for Freeway Work-zone Approaches. Paper presented at the 80th Annual Meeting of the Transportation Research Board, Washington, D.C., 2001.
5. McCoy, P.T., G. Pesti, and P.S. Byrd. *Alternative Information to Alleviate Work Zone-Related Delays*. SPR-PL-1(35)P513. University of Nebraska, Lincoln, 1999.
6. Finley, M.D., G.L. Ullman, and C.L. Dudek. Sequential Warning-Light System for Work-Zone Lane Closures. In *Transportation Research Record 1509*. Transportation Research Board, Washington, D.C., 1995, pp. 39-45.
7. Fontaine, M.D., P.J. Carlson, and H.G. Hawkins. *Evaluation of Traffic Control Devices for Rural High-Speed Maintenance Work Zones: Second Year Activities and Final Recommendations*. Report 1879-2. Texas Transportation Institute, College Station, 2001.
8. Transportation Research Board. *Highway Capacity Manual 2000*. Washington, D.C., 2000.
9. Krammes, R.A., G.L. Ullman, J.L. Memmott, and C.L. Dudek. *User's Manual for QUEWZ-92*. Report 1106-7. Texas Transportation Institute, College Station, January 1993.
10. Pal, R., and K.C. Sinha. Analysis of Crash Rates at Interstate Work Zones in Indiana. In *Transportation Research Record 1529*. Transportation Research Board, Washington, D.C., 1996, pp. 43-53.

11. Ha, T-J., and Nemeth, Z.A. Detailed Study of Accident Experience in Construction and Maintenance Zones. In *Transportation Research Record 1509*. Transportation Research Board, Washington, D.C., 1995, pp. 38-45.
12. Garber, N.J., and M. Zhao. Distribution and Characteristics of Crashes at Different Work Zone Locations in Virginia. In *Transportation Research Record 1794*. Transportation Research Board, Washington, D.C., 2002, pp. 19-25.
13. Benekohal, R.F., E. Shim, and P.T.V. Resende. Truck Drivers' Concerns in Work Zones: Travel Characteristics and Accident Experiences. In *Transportation Research Record 1509*. Transportation Research Board, Washington, D.C., 1995, pp. 55-64.
14. Plummer, S.R., K.A. Andersen, Y.H. Wijaya, and P.T. McCoy. Effect of Freeway Work Zones on Fuel Consumption. In *Transportation Research Record 901*. Transportation Research Board, Washington, D.C., 1983, pp. 11-17.
15. Wells-Parker, E., J. Ceminsky, V. Hallberg, R.W. Snow, G. Dunaway, S. Guiling, M. Williams, and B. Anderson. An Exploratory Study of the Relationship Between Road Rage and Crash Experience in a Representative Sample of U.S. Drivers. *Accident Analysis and Prevention*, Vol. 34, No. 3, 2002, pp. 271-278.
16. McCoy, P.T., and G. Pesti. Dynamic Late Merge Control Concept for Work Zones on Rural Interstate Highways. Paper presented at the 80th Annual Meeting of the Transportation Research Board, Washington, D.C., 2001.
17. Tarko, A., and S. Venugopal. *Safety and Capacity Evaluation of the Indiana Lane Merge System*. FHWA/IN/JTRP-2000/19. Purdue University, West Lafayette, Ind., 2001.
18. Wayne State University, Department of Civil and Environmental Engineering. *Dynamic Lane Merge Traffic Control System: A Strategy for Alleviating Aggressive Driver Behavior at Work Zones in Michigan*. Interim Report. Detroit, Mich., 2001.
19. Byrd, P.S., G. Pesti, D.S. Jessen, and P.T. McCoy. Driver Survey of the Late-Merge Work Zone Traffic Control Strategy. Paper presented at the 78th Annual Meeting of the Transportation Research Board, Washington, D.C., 1999.
20. Beacher, A.G. *Improving Flow at Work Zone Lane Closures: Evaluation of the Late Merge Concept*. University of Virginia, Charlottesville, 2004.

APPENDIX A

STATISTICAL ANALYSIS OF MUTCD SIMULATION: TWO-FACTOR INTERACTIONS

Table A-1. Throughput Descriptive Statistics for MUTCD Control and Free Flow Speed by Lane Configuration Interaction

Free flow Speed (mph)	Lane Configuration	Mean Throughput (vph)	95% Confidence Interval	
			Lower Bound (vph)	Upper Bound (vph)
60	2-to-1	1265.98	1262.66	1269.29
	3-to-1	1159.19	1155.88	1162.51
	3-to-2	2296.09	2292.78	2299.41
70	2-to-1	1272.47	1269.15	1275.79
	3-to-1	1148.32	1145.00	1151.64
	3-to-2	2312.46	2309.14	2315.77

Table A-2. Throughput Descriptive Statistics for MUTCD Control and Free Flow Speed by Percentage of Heavy Vehicles Interaction

Free flow Speed (mph)	% Heavy Vehicles	Mean Throughput (vph)	95% Confidence Interval	
			Lower Bound (vph)	Upper Bound (vph)
60	0	1681.43	1677.60	1685.26
	10	1603.72	1599.89	1607.55
	20	1538.11	1534.28	1541.94
	30	1471.76	1467.93	1475.58
70	0	1700.17	1696.34	1704.00
	10	1604.43	1600.50	1608.16
	20	1540.32	1536.49	1544.15
	30	1466.18	1462.35	1470.01

Table A-3. Throughput Descriptive Statistics for MUTCD Control and Lane Configuration by Percentage of Heavy Vehicles Interaction

Lane Configuration	% Heavy Vehicles	Mean Throughput (vph)	95% Confidence Interval	
			Lower Bound (vph)	Upper Bound (vph)
2-to-1	0	1343.32	1338.63	1348.01
	10	1273.90	1269.21	1278.59
	20	1243.05	1238.36	1247.74
	30	1216.63	1211.94	1221.32
3-to-1	0	1289.33	1284.64	1294.01
	10	1203.52	1198.83	1208.21
	20	1115.59	1110.90	1120.28
	30	1006.59	1001.90	1011.28
3-to-2	0	2439.76	2435.07	2444.45
	10	2334.65	2329.96	2339.34
	20	2259	2254.41	2263.69
	30	2183.69	2179.00	2188.38

Table A-4. Throughput Descriptive Statistics for MUTCD Control and Free Flow Speed by Demand Volume Interaction

Free flow Speed (mph)	Demand Volume	Mean Throughput (vph)	95% Confidence Interval	
			Lower Bound (vph)	Upper Bound (vph)
60	500	1181.04	1177.21	1184.87
	1000	1707.73	1703.90	1711.56
	1500	1710.67	1706.84	1714.50
	2000	1695.58	1691.75	1699.40
70	500	1176.17	1172.34	1180.00
	1000	1708.66	1704.83	1712.49
	1500	1713.91	1710.08	1717.73
	2000	1712.27	1708.44	1716.10

Table A-5. Throughput Descriptive Statistics for MUTCD Control and Lane Configuration by Demand Volume Interaction

Lane Configuration	Demand Volume (vphpl)	Mean Throughput (vph)	95% Confidence Interval	
			Lower Bound (vph)	Upper Bound (vph)
2-to-1	500	1008.38	1003.69	1013.07
	1000	1355.11	1350.42	1359.80
	1500	1356.78	1352.09	1361.46
	2000	1356.63	1351.94	1361.32
3-to-1	500	1024.03	1019.34	1028.72
	1000	1197.7	1193.01	1202.39
	1500	1208.47	1203.78	1213.16
	2000	1184.83	1180.14	1189.51
3-to-2	500	1503.4	1498.71	1508.09
	1000	2571.77	2567.08	2576.46
	1500	2571.63	2566.94	2576.31
	2000	2570.31	2565.62	2575.00

Table A-6. Throughput Descriptive Statistics for MUTCD Control and Percent Heavy Vehicles by Demand Volume Interaction

% Heavy Vehicles	Demand Volume (vphpl)	Mean Throughput (vph)	95% Confidence Interval	
			Lower Bound (vph)	Upper Bound (vph)
0	500	1212.4	1206.99	1217.81
	1000	1856.14	1850.72	1861.55
	1500	1856.48	1851.06	1861.89
	2000	1838.19	1832.77	1843.60
10	500	1182.76	1177.35	1188.18
	1000	1739.99	1734.58	1745.4
	1500	1747.18	1741.77	1752.60
	2000	1746.16	1740.74	1751.57
20	500	1167.18	1161.76	1172.59
	1000	1664.13	1658.72	1669.55
	1500	1666.31	1660.89	1671.72
	2000	1659.23	1653.82	1664.65
30	500	1152.08	1146.66	1157.49
	1000	1572.51	1567.09	1577.92
	1500	1579.19	1573.77	1584.60
	2000	1572.11	1566.69	1577.52

APPENDIX B

STATISTICAL ANALYSIS OF LATE MERGE SIMULATION: TWO-FACTOR INTERACTIONS

Table B-1. Throughput Descriptive Statistics for Late Merge Control and Free Flow Speed by Lane Configuration Interaction

Free flow Speed (mph)	Lane Configuration	Mean Throughput (vph)	95% Confidence Interval	
			Lower Bound (vph)	Upper Bound (vph)
60	2-to-1	1274.48	1269.10	1279.86
	3-to-1	1282.48	1277.10	1287.85
	3-to-2	2268.47	2263.09	2273.84
70	2-to-1	1274.47	1269.09	1279.84
	3-to-1	1287.63	1282.25	1293.01
	3-to-2	2289.41	2284.04	2294.79

Table B-2. Throughput Descriptive Statistics for Late Merge Control and Free Flow Speed by Percentage of Heavy Vehicles Interaction

Free flow Speed (mph)	% Heavy Vehicles	Mean Throughput (vph)	95% Confidence Interval	
			Lower Bound (vph)	Upper Bound (vph)
60	0	1700.62	1694.41	1706.83
	10	1640.14	1633.94	1646.35
	20	1578.13	1571.92	1584.44
	30	1515.01	1508.80	1521.21
70	0	1727.88	1721.67	1734.09
	10	1648.98	1642.77	1655.19
	20	1580.2	1573.99	1586.41
	30	1511.62	1505.41	1517.83

Table B-3. Throughput Descriptive Statistics for Late Merge Control and Lane Configuration by Percentage Heavy Vehicles Interaction

Lane Configuration	% Heavy Vehicles	Mean Throughput (vph)	95% Confidence Interval	
			Lower Bound (vph)	Upper Bound (vph)
2-to-1	0	1333.65	1326.04	1341.25
	10	1279.70	1272.10	1287.31
	20	1252.85	1245.25	1260.46
	30	1231.69	1224.08	1239.29
3-to-1	0	1457.43	1449.82	1465.03
	10	1358.70	1351.10	1366.31
	20	1225.45	1217.85	1233.06
	30	1098.62	1091.02	1106.23
3-to-2	0	2351.67	2344.06	2359.27
	10	2295.28	2287.68	2302.89
	20	2259.18	2251.58	2266.79
	30	2209.63	2202.02	2217.23

Table B-4. Throughput Descriptive Statistics for Late Merge Control and Free Flow Speed by Demand Volume Interaction

Free flow Speed (mph)	Demand Volume	Mean Throughput (vph)	95% Confidence Interval	
			Lower Bound (vph)	Upper Bound (vph)
60	500	1269.09	1262.89	1275.30
	1000	1721.41	1715.20	1727.61
	1500	1720.27	1714.06	1726.48
	2000	1723.13	1716.92	1729.33
70	500	1262.82	1256.61	1269.03
	1000	1735.20	1728.99	1741.41
	1500	1735.56	1729.35	1741.76
	2000	1735.10	1728.89	1741.31

Table B-5. Throughput Descriptive Statistics for Late Merge Control and Lane Configuration by Demand Volume Interaction

Lane Configuration	Demand Volume (vphpl)	Mean Throughput (vph)	95% Confidence Interval	
			Lower Bound (vph)	Upper Bound (vph)
2-to-1	500	1002.48	994.88	1010.09
	1000	1364.55	1356.94	1372.15
	1500	1365.30	1357.70	1372.91
	2000	1365.56	1357.95	1373.16
3-to-1	500	1294.98	1287.37	1302.58
	1000	1282.38	1274.78	1289.99
	1500	1279.31	1271.70	1286.91
	2000	1283.54	1275.94	1291.15
3-to-2	500	1500.41	1492.80	1508.01
	1000	2537.98	2530.38	2545.59
	1500	2539.13	2531.52	2546.73
	2000	2538.24	2530.64	2545.85

Table B-6. Throughput Descriptive Statistics for Late Merge Control and Percentage of Heavy Vehicles by Demand Volume Interaction

% Heavy Vehicles	Demand Volume (vphpl)	Mean Throughput (vph)	95% Confidence Interval	
			Lower Bound (vph)	Upper Bound (vph)
0	500	1320.07	1311.29	1328.85
	1000	1845.02	1836.24	1853.80
	1500	1846.22	1837.44	1855.00
	2000	1845.68	1836.90	1854.46
10	500	1285.22	1276.44	1294.00
	1000	1763.54	1754.76	1772.32
	1500	1764.42	1755.64	1773.20
	2000	1765.08	1756.30	1773.86
20	500	1255.59	1246.81	1264.47
	1000	1692.02	1683.24	1700.80
	1500	1681.04	1672.26	1689.82
	2000	1688.01	1679.23	1696.79
30	500	1202.94	1194.16	1211.73
	1000	1612.64	1603.86	1621.43
	1500	1619.97	1611.19	1628.75
	2000	1617.68	1608.90	1626.46