

**FINAL REPORT**

**A SURVEY OF MASONRY AND CONCRETE ARCH BRIDGES IN VIRGINIA**

**Ann B. Miller**  
**Research Scientist**

**Kenneth M. Clark**  
**Research Associate**

**Matthew C. Grimes**  
**Research Assistant**

(The opinions, findings, and conclusions expressed in this report are those of the authors and not necessarily those of the sponsoring agencies)

Virginia Transportation Research Council  
(A Cooperative Organization Sponsored Jointly by the  
Virginia Department of Transportation and  
the University of Virginia)

In Cooperation with the U.S. Department of Transportation  
Federal Highway Administration

Charlottesville, Virginia

February 2000  
VTRC 00-R11

Copyright 2000 by the Virginia Department of Transportation.

## **VIRGINIA HISTORIC STRUCTURES TASK GROUP**

ANN B. MILLER (Chair), Research Scientist, Virginia Transportation Research Council

WILLIAM H. BUSHMAN, Research Scientist, Virginia Transportation Research Council

JOHN R. DEWELL, Assistant State Hydraulics Engineer, Virginia Department of Transportation

G. MICHAEL FITCH, Senior Research Scientist, Virginia Transportation Research Council

THOMAS F. LESTER, Structural Engineer Supervisor, Virginia Department of Transportation

CLAUDE S. NAPIER, JR., Division Bridge Engineer, Federal Highway Administration

ANTONY F. OPPERMAN, Cultural Resource Program Manager, Virginia Department of Transportation

EDWARD S. SUNDRA, Environmental Engineer, Federal Highway Administration

JOHN E. WELLS, Architectural Historian, Virginia Department of Historic Resources

## **ABSTRACT**

Under the National Historic Preservation Act of 1966, older bridges being considered for upgrading or replacement must be evaluated for historic significance. The Virginia Transportation Research Council conducted a study of Virginia's pre-1932 masonry and concrete arch bridges during the 1980s; however, no comprehensive study of post-1932 bridges has been subsequently undertaken. This study rectifies the lack of information on post-1932 arch bridges and establishes a historic context for Virginia's arch bridges.

The project consisted of a field survey, documentary research into arch bridge types, data tabulation, and a comparison of the resulting information on arch bridge chronology and technology. The data were evaluated for historic significance by the Historic Structures Task Group (an interdisciplinary historic transportation study committee) and the State Historic Preservation Officer. Of the 127 existing arch bridges under VDOT's purview, 21 were found to be eligible for the National Register of Historic Places. This project identified VDOT's significant arch bridges and cleared the remainder of the bridges for necessary maintenance and upgrade.

## **FINAL REPORT**

### **A SURVEY OF MASONRY AND CONCRETE ARCH BRIDGES IN VIRGINIA**

**Ann B. Miller**  
**Research Scientist**

**Kenneth M. Clark**  
**Research Associate**

**Matthew C. Grimes**  
**Research Assistant**

## **INTRODUCTION**

Reliable bridges are an essential and integral component of a safe transportation system. However, as our transportation system ages, many bridges are becoming obsolete. This obsolescence is a result of natural deterioration, of the materials used in construction, and of earlier design standards that no longer accommodate the speed, dimensions, loads, and volume of modern traffic demands. However, in addition to safety, there is another factor to be considered in the case of older bridges: under the National Historic Preservation Act of 1966, older bridges being considered for upgrading or replacement must be evaluated for historic significance. In this context, historically significant structures are eligible for the National Register of Historic Places. This survey addresses which bridges are historically significant—i.e., which bridges provide valuable information about our cultural heritage, including architectural uniqueness, innovations in engineering, and evolution of the transportation system—and which bridges are merely old, but not necessarily historically significant.

This report expands the available information on Virginia's arch bridges. It also addresses questions of historic significance pertaining to these masonry and concrete arch bridges owned by the Virginia Department of Transportation. This project continued as well as updated the survey of arch bridges undertaken for the Virginia Transportation Research Council (VTRC) during the 1980s by Paula A. C. Spero (Spero, 1984). (The term "survey" is used in the historic preservation sense, indicating an inventory of physical characteristics and historic backgrounds of certain types of structures, e.g., arch bridges.) During the 1980s survey, Virginia's pre-1932 arch bridges were inventoried and analyzed, providing coverage of arch bridges constructed prior to the 1932 consolidation of the state and county road systems under the State Department of Highways. A total of 166 bridges, restricted to the bridges of the pre-1932 date, were surveyed during this initial project in the 1980s. However, no comprehensive study of later bridges was undertaken.

The current project, carried out in 1996 to 1999 and covered in the present report, brought the survey forward from 1932 and also updated the previous survey. The current survey covered all 127 arch bridges and culverts under VDOT's purview; in addition, approximately 60 non-VDOT arch bridges (private, abandoned, railroad, and federally owned structures) were also surveyed in order to provide the most accurate possible context. The update of the 1980s survey involved a complete field survey of post-1932 arch bridges as well as a revisit of surviving pre-1932 bridges that had been previously surveyed. The 1980s survey also noted changes that have occurred in the intervening decade-and-a-half. This report includes an updated inventory, historic context of arch bridge structure and technology, an overview of Virginia's arch bridges, and an evaluation of all arch bridges under VDOT's purview for historic significance.

### **PURPOSE AND SCOPE**

The purpose of this project was to identify and categorize masonry and concrete arch bridge structures within VDOT's transportation system and to determine which of these structures are historically significant. This project built on the information gathered during VTRC's 1980s survey of pre-1932 arch bridges.

This current project had three objectives:

1. To update the information on pre-1932 arch bridges included in the earlier survey;
2. To extend the survey to include Virginia's post-1932 arch bridges;
3. To provide a comprehensive evaluation of all surviving arch bridges in Virginia under VDOT's purview and determine which bridges are historically significant (e.g., which structures are eligible for the National Register). The bridges that were identified as significant will be incorporated into a historic bridge management system.

### **RESEARCH DESIGN AND METHODOLOGY**

The research design for this project followed closely the successful non-arched concrete bridge survey completed by VTRC from 1992 through 1996. An inventory of all highway arch bridges in Virginia was obtained from VDOT bridge files. The inventory was broken down by construction district and by county within each construction district. Initially, bridges were located on county maps. Next, each bridge was field-surveyed to obtain the necessary data for describing the bridge and was evaluated for its historic significance. This information was subsequently collated for presentation to an interdisciplinary study committee, which reviewed and evaluated the information from this survey to determine Virginia's historically significant arch bridges.

The National Register program is the recognized basis for making decisions concerning historic significance. Generally, to be considered historically significant, a structure must be 50 years of age or older and fulfill one or more of the following criteria: it must be associated with the events or the lives of persons significant in our past; it embodies the distinctive characteristics of type, period, or method of construction; it represents the work of a master; it possesses high artistic values; or, it has yielded, or may be likely to yield, information important to history or prehistory. For evaluation of the arch bridges based on these criteria, a preexisting committee, the Historic Structures Task Group, was utilized. This interdisciplinary group includes members with backgrounds in engineering, history, archaeology, and architectural history, representing VTRC, VDOT, the Department of Historic Resources (DHR), and the Federal Highway Administration (FHWA).

The research methodology included the following tasks:

1. *Establish the historic period of bridge construction to be studied.* The previous survey of Virginia's arch bridges completed by VTRC in the 1980s included only bridges built prior to 1932. Since a structure generally has to be at least 50 years old to be considered historically significant, a field survey had to cover all structures 50 years and older in order to yield information useful for determining potential historic significance. Since the majority of arch bridges in Virginia were constructed prior to 1950, it was decided to include all arch bridges in the survey. In order to establish a comprehensive historic context for arch bridges in Virginia, a survey was conducted that covered arch bridges under VDOT's purview as well as other arch bridges (such as railroad bridges, private, and abandoned bridges). Only the bridges that were under VDOT's purview were evaluated for historic significance. The resulting data provides information for comparing all existing arch bridges in Virginia, and not merely those bridges built prior to 1932. Including all existing arch bridges in the survey eliminated the need for additional survey work on arch bridges.
2. *Select the geographic area to be studied.* In order to complete a comprehensive survey and evaluation of Virginia's arch bridges, it was decided to study every one of the arch bridges throughout all of VDOT's construction districts.
3. *Generate an inventory of all arch bridges currently on-system.* The Structure and Bridge Division of VDOT supplied a comprehensive inventory of bridges in each construction district throughout the state. Bridges in this inventory were located on county maps for use in the survey.

4. *Decide upon the data to be obtained on each site.* A standardized survey/inventory form for arch bridges used during the 1980s survey was updated for use in this survey (APPENDIX A). A supplementary form was utilized in cases where previous survey data existed; where no previous survey had been done, the updated form based on the earlier form was used. The information gathered included:
  - Geographic location
  - Engineering profile, including: designer (if known), builder (if known), date of construction, date of reconstruction, design and technological data, physical description, photographic documentation of bridge, etc.
  - Historic context, including: photographs of associated buildings and surroundings, documentation of historical relevance, etc.
5. *Conduct the survey.* Several teams, each consisting of a researcher and a technician, conducted the survey. Prior to the commencement of the study, field trips were made to bridges previously identified as historically significant. These field trips were intended to more fully train the team members in the practices associated with arch bridge survey techniques, including recognizing bridge types, structural elements, and terminology. In addition, other documentary evidence, including the corresponding VDOT bridge files for each structure, was reviewed; construction and inspection data were identified and added to the field survey information.
6. *Organize the field and documentary data.* The information was organized by bridge type, date, and historic background by members of the survey teams. It was then presented to the Historic Structures Task Group. To facilitate comparison and evaluation of the bridges, these categories included:
  - County/city code
  - Bridge number
  - Route
  - Construction date
  - Material (i.e., masonry or concrete)
  - Arch type
  - Total number of bridge spans



- Length
  - Designer/builder information.
7. *Evaluate the bridges for historic significance.* The data gathered in the course of the survey, and the results of the historic research into arch bridges in general (and for Virginian arch bridges in particular), was used to produce a historic context for arch bridges in Virginia. This context, as with any historic context, was vital in determining a bridge's relation to other similar structures in Virginia and in establishing whether a bridge was historically significant or not. Using data from the field survey and associated historic research and context, the Historic Structures Task Group met on several occasions in 1997, 1998, and early 1999 and evaluated the bridges under VDOT's purview regarding their eligibility for the National Register of Historic Places. The Task Group determined that the criteria that had been successfully used by the Group in the previous survey for evaluating Virginia's non-arched concrete, metal truss, and movable span bridges could again be used to determine the historic significance of masonry and concrete arch bridges and other types of bridges for this current survey. This resulted in a single set of criteria for evaluating all bridges in Virginia (Miller, McGeehan and Clark, 1996; Miller and Clark, 1997 and 1998). The results of these evaluations were then presented to the Virginia Department of Historic Landmarks Evaluations Team, which has agreed to accept the recommendations of the Task Group in dealing with questions of historic significance of transportation structures.

## **HISTORIC CONTEXT**

### **Construction Districts**

Until the early 20th century, road and bridge construction was almost exclusively under the control of the counties where they were located. Virginia's highway construction districts came into existence as a result of the 1922 departmental reorganization. Earlier attempts to develop construction "divisions" within Virginia had failed primarily due to the shortages and disruptions in materials and manpower imposed by World War I. The establishment of the 1922 construction districts most likely grew out of the needs of the State Highway System, which was created in 1918.

Virginia currently has nine construction districts: Staunton, Culpeper, Northern Virginia (NOVA), Fredericksburg, Suffolk, Richmond, Lynchburg, Salem, and Bristol (Figure 1).

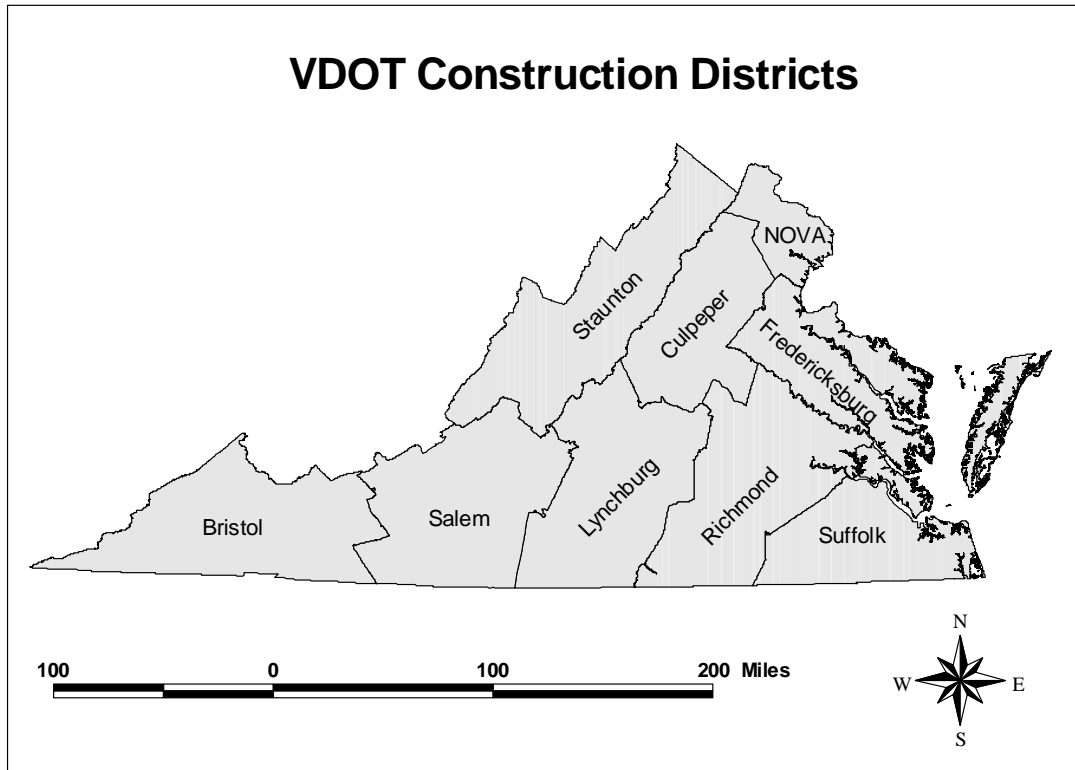

**Figure 1. VDOT Construction Districts**

*The Staunton District* encompasses the Shenandoah Valley north of the James River as well as Highland, Bath, and Alleghany counties. When created in 1922, this district also contained Albemarle County (which was later made a part of the Culpeper District). The Staunton Construction District currently covers the counties of Frederick, Clarke, Warren, Shenandoah, Page, Rockingham, Augusta, Rockbridge, Highland, Bath, and Alleghany.

*The Culpeper District* covers the north central Piedmont area. When created in 1922, this district contained Fluvanna, Louisa, Orange, Greene, Madison, Culpeper, Rappahannock, Fauquier, Prince William, Loudoun, Arlington, and Fairfax counties. There have been two changes to the Culpeper District since its inception. Albemarle County, which was originally part of the Staunton District, subsequently was made a part of the Culpeper District. The Northern Virginia (NOVA) District was created from the Culpeper District in the mid-1980s. The Culpeper construction district currently covers the counties of Albemarle, Fluvanna, Louisa, Orange, Greene, Madison, Culpeper, Rappahannock, and Fauquier.

The Northern Virginia (NOVA) District is the most recently created district. The intensive urbanization of northern Virginia in the last half of the 20th century and the attendant population growth in that region produced the need for the separate administration of the northern portion of the Culpeper District: Prince William, Loudoun, Arlington, and Fairfax were cut off from this district to form the Northern Virginia District in 1984.

The *Fredericksburg District* includes the region lying south of the Potomac River and north of the York River and its branches. This district is comprised of the counties of Stafford, King George, Westmoreland, Northumberland, Lancaster, Richmond, Gloucester, Mathews, Middlesex, Essex, King and Queen, King William, Caroline, and Spotsylvania.

The *Suffolk District* encompasses southeast Virginia and the Eastern Shore. At its formation in 1922, this district contained the counties of James City, York, Warwick, Elizabeth City, Princess Anne, Norfolk, Nansemond, Accomack, Northampton, Isle of Wight, Southampton, Surry, Sussex, and Greensville. After World War II, the old counties of Warwick, Elizabeth City, Princess Anne, Norfolk, and Nansemond underwent intense urbanization and development as industrial and recreational centers. These counties eventually ceased to exist, becoming the independent cities of Newport News, Hampton, Virginia Beach, Chesapeake, Norfolk, Portsmouth, and Suffolk. The urbanization of these counties has produced two distinct regions within the district: the highly developed southeastern section and the primarily rural Eastern Shore and counties west of Suffolk.

The *Richmond District* contains the counties of Goochland, Hanover, New Kent, Charles City, Henrico, Powhatan, Chesterfield, Prince George, Amelia, Nottoway, Dinwiddie, Lunenburg, Mecklenburg, and Brunswick.

The *Lynchburg District* includes the south-central portion of Virginia—the counties of Nelson, Buckingham, Cumberland, Appomattox, Prince Edward, Campbell, Charlotte, Pittsylvania, and Halifax.

The *Salem District* contains Botetourt, Bedford, Craig, Roanoke, Montgomery, Giles, Pulaski, Floyd, Franklin, Henry, Patrick, and Carroll counties.

The *Bristol District* encompasses southwestern Virginia. This district contains Grayson, Wythe, Bland, Tazewell, Smyth, Washington, Russell, Buchanan, Dickenson, Wise, Scott, and Lee counties.

## Arch Technical Background

The arch is among the most ancient and stable means of supporting a load. Despite its antiquity, the arch form is also among the most complex structures known to modern civil engineers, who have for the most part consigned the arch to architects and historians in favor of structural forms which are easier to construct. The following section explains the terminology, mechanics, and classification of arches, which are illustrated in Figure 2.

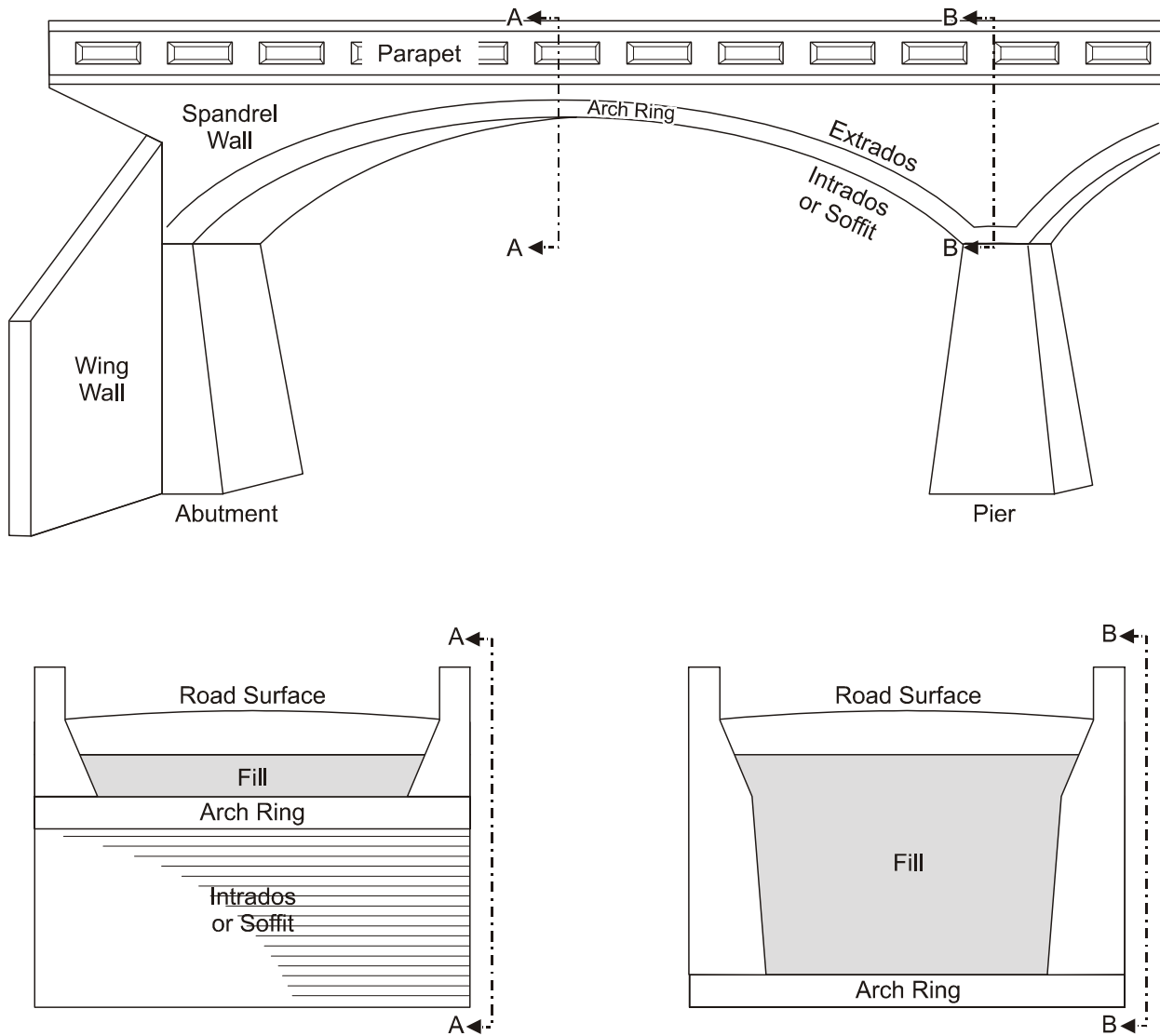

Figure 2. Illustrations with Arched Bridge Terminology

An arched bridge has two main components: the arched member which supports the loads, and the abutments or piers at either end supporting the arch ring. The lower surface of the arch ring is called the intrados, while the upper surface is termed the extrados. Rising from the extrados are spandrel walls or columns which hold the fill (loose material in the gap between the extrados and the road surface) or support the deck upon which vehicles travel.

The primary forces in an arch are tension and compression. Tensile forces have a pulling effect, and failure is characterized by fracturing or tearing. In compression, on the other hand, failure occurs by buckling or crushing. The following discussion of arch mechanics will be easier for the reader to understand if he or she remembers a simple principle: what goes up must come down, or more scientifically, systems tend to reach equilibrium. In building a bridge or other structures, all of the forces caused by the weight of the structure and the loads it bears must be transferred to the ground.

An arch is similar to a chain hanging in a curve between two supports. As long as the links are intact, the chain can support loads. Inverting this system results in an arch. Rather than links pulling upon one another, each element bears upon the one below it. In a simplified model of a semicircular arch made of stone blocks, all forces acting on an arch ring are compressive in nature. A load applied to the crown will be transferred to the ground as each stone presses down upon the stone below. As long as the stones are strong enough to resist crushing, the arch will stand. Like a chain, however, if one block fails, the arch collapses.

In practice, the behavior of arch bridges is not quite so simple. In masonry arches, stones must not only resist crushing due to the compressive forces, but they also must maintain their position within the arch ring. Thus, mortar is used to bed the stones. The arch itself tries to reach a stable equilibrium by flattening out. This tendency to flatten results in an outward thrust, which must be counteracted by abutments or piers at the ends of the arch ring (Figure 3). Tension forces can also develop as the arch flattens. Stone and concrete have relatively low tensile strengths. Mortar-to-stone contact has very low tensile strength under compression, and little or no tensile strength under tension.

The earliest arches were proportioned such that tension forces were negligible. This was accomplished by keeping the arch ring in a semicircular (or nearly so) shape. These types of arches are very stable and produce only small thrusts at the ends; however, the rise-to-span ratios are limited to about 1:5. This is why the magnificent arched structures of classical times, such as the Pont du Gard, are comprised of a series of short spans rather than one or two long ones. The eighteenth century French engineer Jean-Rodolph Perronet was able to increase the rise-to-span ratios of masonry arches to 1:10. His arches are noticeably flatter and more graceful than those of his contemporaries. With the advent of reinforced concrete, which can resist both tension and compression, long, flat arch spans could be efficiently designed and constructed, with rise-to-span ratios on the order of 1:17.

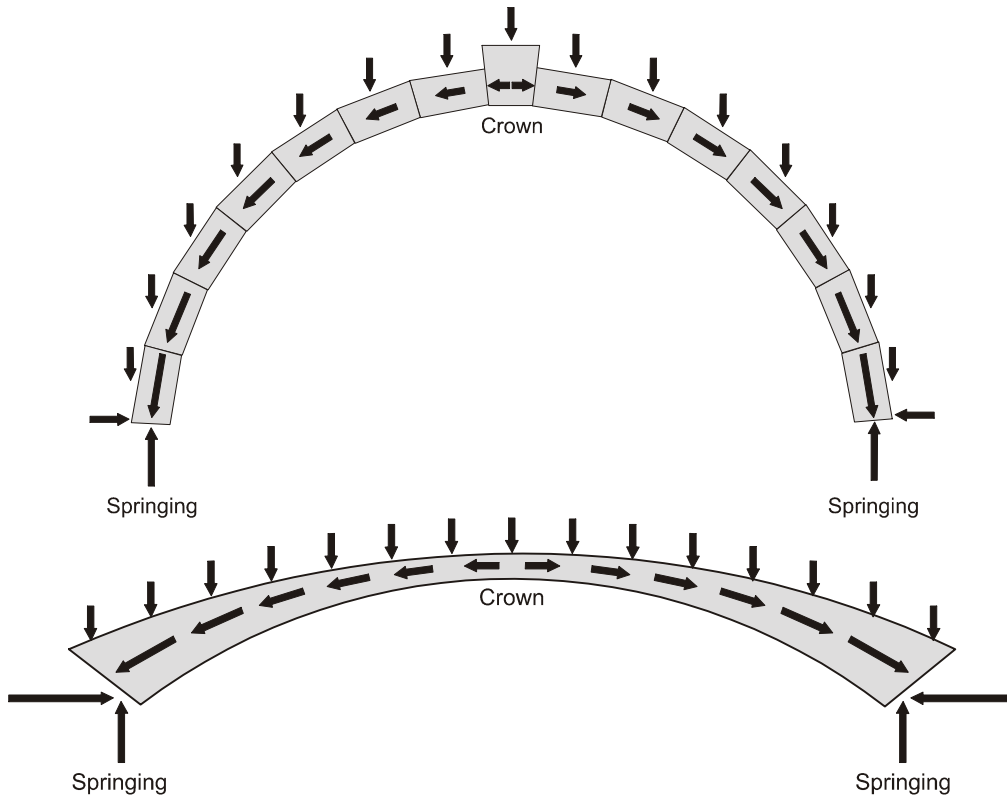

**Figure 3. Comparison of the Relative Magnitudes of the Forces in a Semicircular and a Segmental Arch (A longer, heavier line denotes a larger force; note how the semicircular span directs more force downward and requires less horizontal force from the abutments to resist flattening out)**

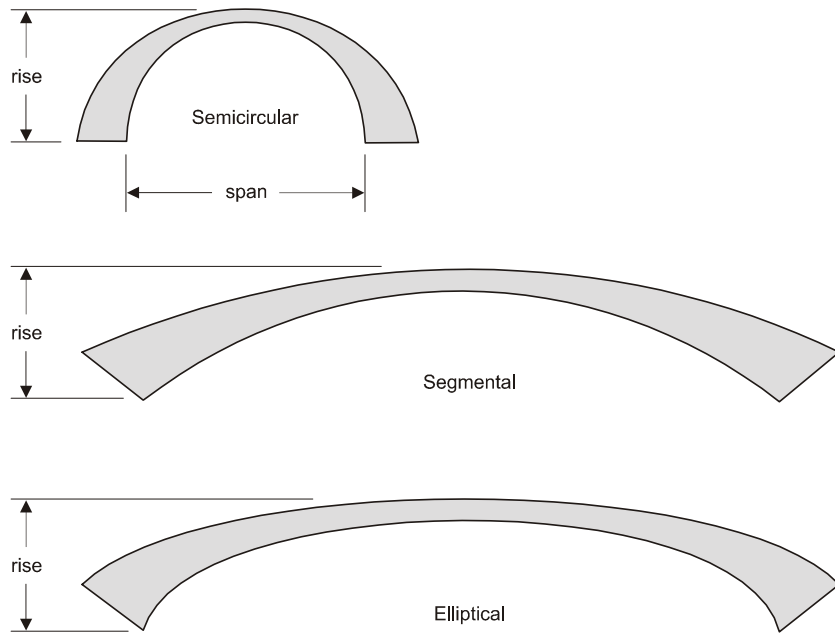

**Figure 4. Geometry of the Arch Ring (Note the greater rise-to-span ratios of the segmental and elliptical arches)**

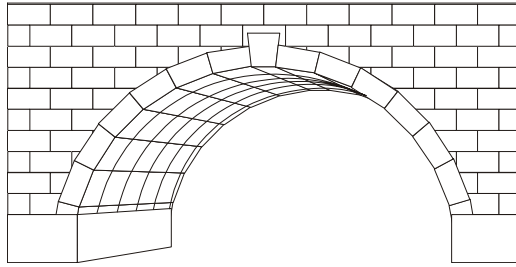

**Figure 5. Masonry Voussoir Arch**  
(Commonly called a barrel vault, due to its resemblance to the inside of a barrel)

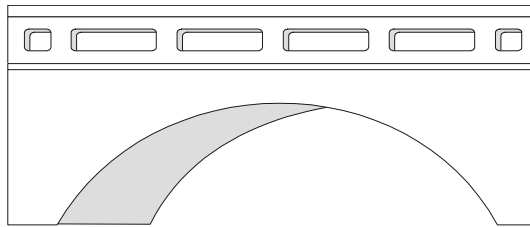

**Figure 6. Closed Spandrel Filled Concrete Arch**

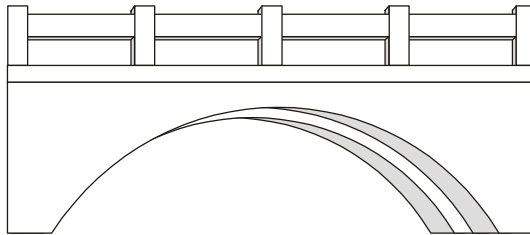

**Figure 7. Closed Spandrel Rib Concrete Arch**

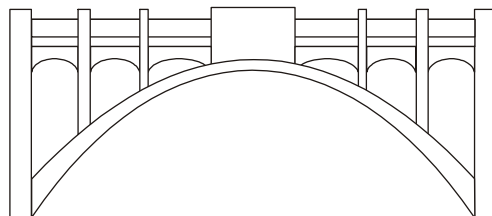

**Figure 8. Open Spandrel Rib Concrete Arch**

Arches can be described by the geometry and the design of the arch ring. The simplest and most stable arch configuration is semicircular or full-centered, with each point on the arch ring equidistant from a common center. If the arch is described by a circular arc of less than 180 degrees, the arch is considered to be segmental. This configuration, as well as arches with elliptical shapes, allow for longer spans and therefore lower rise-to-span ratios (Figure 4). The flatter configurations also develop more tension in the arch ring and require heavier abutments to resist their thrust.

A masonry arch resembling the inside of a barrel, having a continuous ring across the width, is called a voussoir arch or barrel vault (Figure 5). (Voussoirs are any of the wedge-shaped stones of which an arch or vault is built.) Such arches are typically closed spandrel filled arches, meaning that solid walls rise from the extrados and contain dirt, rubble, or stones, which cover the ring and provide a level road surface. Most masonry arches, including all of the masonry arches in Virginia, are closed spandrel filled voussoir arches.

The use of concrete permits more variation and greater economy of material in arch design. Early concrete arches mimicked stone designs and used the barrel vault configuration (Figure 6). However, engineers quickly learned to save materials by eliminating the fill and supporting the bridge deck by discreet walls built across the width of the arch. An even more economical design is the rib arch, wherein the voussoirs are replaced by discreet arch rings. Rib arches can have closed spandrels, with the ribs supporting solid spandrel walls, which in turn support the bridge deck and roadway (Figure 7). Rib arches can also have open spandrels, with columns rising from the extrados to support the deck structure (Figure 8). One relatively rare form of open spandrel rib arch is the through arch (also sometimes known as the rainbow or Marsh arch), where the crown of the arch rings rises above the roadway on either side, with the deck load being suspended from the arch by a series of vertical hangers. Though once common, particularly throughout the Midwest, many of these through arches have been demolished as roads have been widened to accommodate modern traffic.

Another type of bridge included in this survey is the arched rigid frame. These structures appear to be arches in shape, but are distinct in mechanical behavior. A complete description of rigid frame mechanics is beyond the scope of this report, but it is sufficient to say that rigid frames resist bending moments as well as axial tension and compressive forces. These structures do not have the discreet components of arch ring and abutments; rather, everything is united into a single complex structural system. This results in greater structural efficiency and economy of materials. To the untrained eye, however, an arched rigid frame may appear no different than a true arch.

### **General History of the Arch**

With its beginnings in antiquity and its fullest development in modern practice, the arch spans the ages as gracefully as it spans deep crevasses and broad rivers. No other structural form has proven to be so durable. Arch construction materials have evolved from dry-laid rubble masonry to prestressed, reinforced concrete, and arch theory has progressed from an empirical



understanding to modern computerized analysis. The writings and existing structures of the ancients reveal, however, that durable arches can be built without modern technology.

The Roman engineers, in particular, were masters of the arch form. Their arched bridges and aqueducts have lasted for over two millennia, not only because they were made of durable materials, but also because they combined innovations in construction technology with centuries of experience and empirical knowledge. The Romans most likely adopted their barrel arches from Sumerian brick arches, which would have existed in their day (Hopkins, 1970). The writings of Vitruvius, the first century BC architect and historian, reveal that Roman engineers had a firm, if empirical, understanding of arch structural principles.

Roman arched bridges were typically semicircular, with massive abutments and wide piers, which were typically one-fourth to one-third the width of the clear span. This ratio was based on trial and error and used extensively from the fourth century BC. The wide piers greatly constricted the waterway and caused flooding problems, which were slightly alleviated by the inclusion of flood openings in the spandrel walls above the piers. In Book VI, Chapter VIII of *Ten Books on Architecture*, Vitruvius describes the need for abutments to be more massive than piers to resist the lateral thrust of the voussoirs. From these writings, historians speculate that Romans engineers may have understood that the lateral thrusts of equally proportioned arches will cancel each other out, allowing for slender piers between spans. However, they probably built their bridges with such heavy piers so that one span could be destroyed for military strategic reasons without the entire bridge collapsing. The heavy piers also enabled them to construct one arch at a time, rather than having to erect all spans simultaneously, so that lateral thrusts would be balanced when the centering was removed (Hopkins, 1970).

Rather than build a bridge entirely out of cut stone, which is expensive and time-consuming, Roman bridge engineers often built filled arches. Spandrel walls were built above the outermost arch rings, and the interior of the bridge between the extrados and the roadbed was filled with rubble stone and mortar. Roman engineers also developed the cofferdam, which enabled them to construct durable pier foundations on rock beneath the riverbed. If the bedrock was too deep for excavation, the Romans used submerged wooden piles capped with timber or concrete platforms. Their most durable designs used underwater concrete foundations placed by the tremie method. When the Roman Empire disintegrated, their advancements in construction practice and technology were lost, and it was many centuries before their most important discovery, concrete, was reinvented.

Medieval arches either crudely imitated Roman designs or made use of the ogival (pointed) designs of oriental tradition (McCullough and Thayer, 1948). The ogival arches often necessitated steeply sloped bridges and approaches with a great waste of masonry; however, lateral thrust was reduced with the ogival designs. An important advancement of the Middle Ages was the use of the ribbed arch, with thin slabs placed across the ribs to form soffits. This reduced the weight and cost of the bridges.

Most bridges of this period were built with little planning or scientific design. Piers were typically placed where convenient, according to the nature of the river. The uneven proportions of the arch spans created unbalanced lateral thrusts that could only be resisted by very heavy piers. In addition, the need to fortify the bridges against military attack necessitated massive piers that severely constricted the waterway, as in the case of the Old London Bridge. An 1843 survey of this bridge found that the piers and their protective skirts reduced the 971 foot waterway by more than 700 feet, and this constriction occasionally caused the water level to rise by as much as five feet behind the bridge. When the bridge was finally removed, the increased velocity of the freed water caused scour damage to many bridges upstream (Hopkins, 1970).

Rather than content themselves with crude imitations of ancient designs, the natural philosophers of the Renaissance applied themselves to the study of arch theory. In 1675 Sir Robert Hooke, famous for his elastic theory, indicated that he had found “A true mathematical and mechanical form of all manner of Arches for Building, with the true butment necessary to each of them. A Problem which no Architectonic Writer hath ever yet attempted, much less performed” (Hopkins, 1970). Later studies of arch theory were conducted by various English and Continental scientists and theoretical mathematicians during the subsequent century. Few significant practical developments were made until Charles August Coulomb rigorously applied logic and mathematical principles to the problems he had experienced as a professional engineer. He used energy principles to determine the stability and horizontal thrust of the arch, and was the first to recognize the importance of friction. Few natural philosophers of the time recognized the importance of Coulomb’s discoveries due to a rift between theorists and practical scientists as well as personal conflicts within the greater scientific societies. Thomas Young’s work on arches was neglected in a similar manner, in spite of the fact that he had made significant, fundamental assertions about the nature and importance of piers, foundations, and abutments.

The rift between theorists and practical scientists continued to widen, and gradually engineering evolved into a separate profession. The first courses in engineering were taught at military academies in the 15th century. Civil engineering separated from the military and became an organized discipline when the first national corps of civil engineers, the Corps des Ponts et Chaussées, was established in Paris in 1716. The first engineering school, the Ecole des Ponts et Chaussées, was established in 1747 to prepare students for the Corps des Ponts et Chaussées. Its second director, Jean-Rodolph Perronet, is considered the father of modern bridge building because of his technical discoveries and also for the impact he had on successive generations of engineers and bridge builders.

At Mantes, Perronet discovered that piers need only carry vertical loads if the arches on either side are of equal proportions and anchored into the pier at the same level. In this configuration, lateral thrusts cancel each other out because the arches on either side of the pier have the same horizontal force, but in opposing directions. Work at Mantes was begun by Jean Hupeau in 1757, but Perronet did not make his discovery until work had commenced on two of the arches in that location in 1763 (Hopkins, 1970). Perronet also developed methods to build flatter arches with lighter piers and studied construction economics, a subject of great importance to modern engineers.

All of the above innovations had the effect of maximizing the waterway beneath the bridge as well as making the bridges appear more graceful. One disadvantage in using lighter piers was that destruction of one of the arches would destroy the entire bridge. This could be prevented in part by partitioning long bridges into groups of balanced spans, with each group of spans separated by heavy abutment piers. By using this design, total bridge collapses could be prevented, since only a few arches would fall if one were destroyed (Whitney, 1929).

Perronet's discoveries laid the foundation for the modern stone arch. The science of bridge-building was further advanced by Emiland Gauthey's *Traite de la Construction des Ponts*, which for many years was the standard comprehensive reference for bridge design and construction. Gauthey also advanced the design of pier cutwaters, based on experiments performed in a stream near his home (Hopkins, 1970).

The culmination of stone arch development was the open spandrel. In this design, the load of the roadway is carried to the arch by walls or columns. This relieves the arch of the tremendous weight of the fill and makes the bridge much more economical. Further savings of material can be effected by separating the barrel of the arch into parallel rings. Paul Sejourne first used this design in 1899 on his Pont Adolphe, which spans the Petrusse in Luxembourg. At the time, its 280-foot span was the longest in the world (Whitney, 1929). This design was carried over into reinforced concrete bridge design and has been used extensively in modern times. The advent of reinforced concrete structural elements, which cost less and are stronger and easier to construct than stone masonry, relegated masonry to facing and architectural features.

While the great kingdoms and empires of Europe had the resources to build monumental stone-arched bridges, colonial Americans relied mainly on ferries and crude timber bridges to cross rivers. Rather than obstacles to overland travel, navigable rivers were often the principal transportation routes, hence there was little need for large bridges. The abundance of timber in colonial America made wooden beam bridges, and later wooden truss bridges, a popular choice for crossings. Wooden bridges, together with a relatively small number of stone arch bridges, served America's limited network of roads and turnpikes well until the mid-19th century, when the demands of the railroad necessitated new construction methods. As wrought iron and structural steel became more economical, metal replaced wood in truss bridges. Hundreds of bridge companies, each claiming to build the strongest bridge at the lowest cost, competed for railroad and road contracts. A wide array of truss designs were patented as engineers tried to further reduce the amount of steel in a bridge. Metal trusses had the advantage of being fire-resistant (a major drawback with wooden railroad bridges) and more durable than wood, but they still required constant maintenance, especially painting. The high maintenance costs of steel bridges became a notable disadvantage with the advent of reinforced concrete, since concrete bridges require much less upkeep.

Modern structural concrete was first used in non-reinforced adaptations of traditional masonry arch bridges, such as the 1871 Prospect Park Bridge in Brooklyn, New York. However, the lack of reinforcement necessitated the use of massive structural elements and did not allow such bridges to span long distances. It took the development of reinforced concrete in the late 19th century to produce the means to construct versatile and economical concrete bridges.

Reinforced concrete arch bridges predated non-arched concrete bridges in the United States by approximately a decade. The first known reinforced concrete bridge in the country was the 1889 arch in Golden Gate Park in San Francisco, California. The popularity of "ferro-concrete" or "concrete-steel" (reinforced concrete) grew throughout the 1890s, and by 1904, pioneering concrete bridge designer Friedrich (Fritz) von Emperger noted that "Ten years ago the number of concrete-steel bridges was so small that there would have been no difficulty in giving a complete list, whereas now it would be quite impossible to give such a list . . ." The selling points of reinforced concrete included several real and perceived advantages compared to metal truss bridges. Use of concrete bridges offered durability and little or no maintenance as well as less reliance on "big steel" corporations. The reduced dependence on these corporations had a special appeal to many rural/populist interests. In addition to permanence and cost-effectiveness, concrete bridges were also touted as being more aesthetically pleasing and less visually intrusive in rural areas than metal truss bridges (Snyder and Mikesell, 1994).

Following the pattern of metal trusses, concrete design engineers began patenting many new designs for reinforced concrete. Often these designs were of little scientific or technical significance, but were unique enough to receive a patent, enabling the designers to collect royalties from bridge companies using their design. The earliest use of what is today considered reinforced concrete was in 1867, when Joseph Monier, a French gardener, added wire mesh to strengthen his artificial stone planters and flowerpots. His son, Jean Monier, expanded the idea to engineering structures such as bridges, receiving a patent in 1873. Contemporary engineers, used to designing with structural steel, distrusted the slender proportions of bridges using this system, and around 1890 Joseph Melan, an Austrian engineer, devised an improvement in reinforced concrete (Cooper, 1997).

Rather than rely on the combined action of the concrete and wire to resist loads, Melan used rolled steel I-beams as the principle structural element in his arches (Figure 9). These steel ribs were encased in concrete, which stabilized the structure and protected the steel from fire and rust. Tests proved that bridges designed with Melan's method were significantly stronger than Monier bridges.



No. 617,615.

Patented Jan. 10, 1899.

E. THACHER.  
CONCRETE ARCH.

(Application filed Oct. 16, 1896.)

(No Model.)

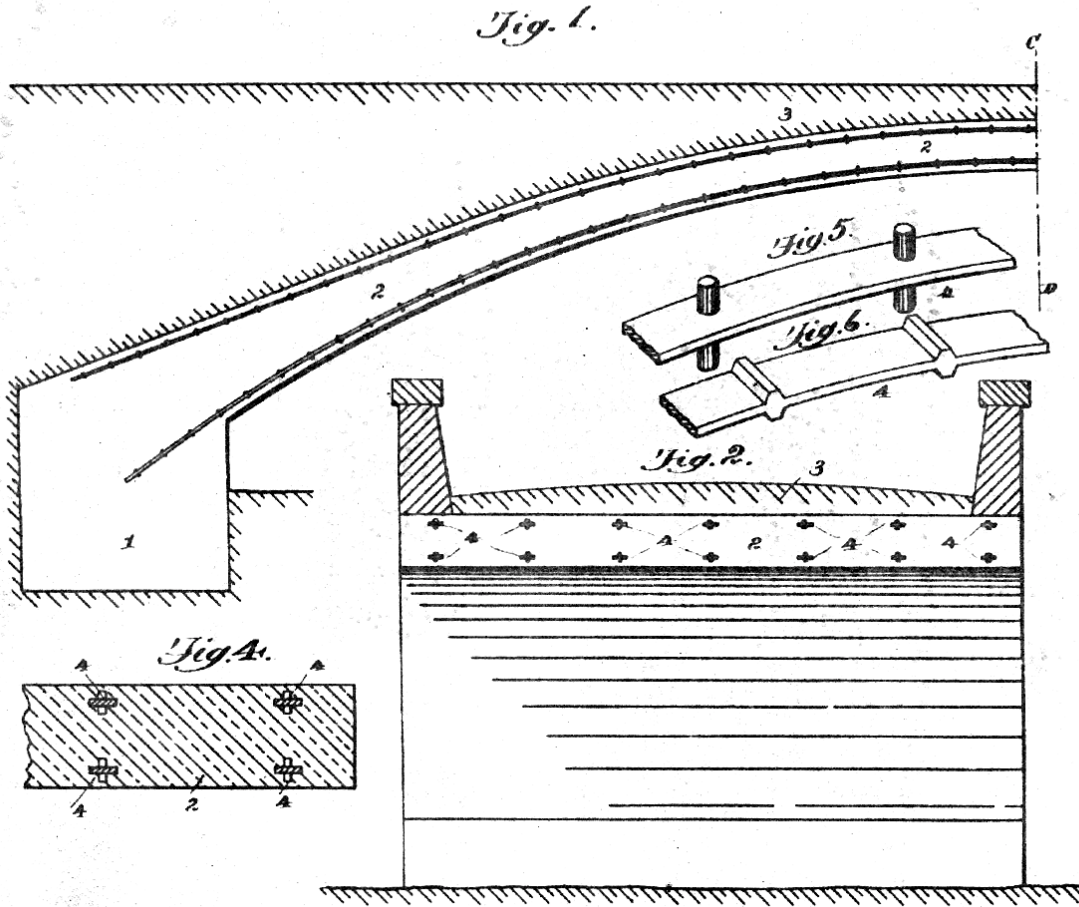

Figure 11. Edwin Thacher's Reinforcing System (which used two tiers of deformed steel bars; this design was widely used after the patent was voided in 1916)

To reduce the amount of steel used in the Melan design, another Austrian engineer, Friedrich (Fritz) von Emperger, replaced the arched steel beams with arched lattice girders. These members were typically formed with two parallel steel angles connected by diagonal rods or bars, which formed an open web (Figure 10). Von Emperger patented his system in America in 1897 and this design became very popular (Cooper, 1997).

The next and perhaps the most significant advancements in reinforced concrete bridge design were made by an American engineer, Edwin Thacher. Thacher was experienced in truss bridge design and held a patent on his own “Thacher Truss.” Thacher’s arch design used parallel rows of bars, which were often connected by stirrups and lateral ties. One bar followed the line of the extrados, while the other was placed close to the intrados of the arch ring (Figure 11). Thacher’s use of bars rather than rolled or built-up shapes, and the placement of bars in parallel layers connected with stirrups, became the basis for modern reinforced concrete arches when his patent was overturned in 1916 by a federal judge.

One of America’s most innovative designers of reinforced concrete arch technology was Daniel B. Luten (APPENDIX B). He rigorously applied theory and test results to develop bridge designs that used much less steel and concrete than his competitors’ designs, while maintaining high standards of strength and durability. Luten protected these innovations with patents, and by 1918 he had received nearly fifty patents for bridge designs and other innovations related to concrete construction. Since his designs were patented, Luten could boldly advertise them in catalogs that were circulated throughout North America and even overseas. He also relied on sales agents and corporate affiliations with construction firms to corner a large share of the bridge market during this period. Several of these affiliated firms used the name “Luten” in their title. Luten bridges had an excellent service record and came with a five-year guarantee against failure. Despite this, Luten’s contemporaries, including influential state and federal engineers, doubted the strength of his slender arches and resented paying patent royalties on designs they considered to be good engineering, but not significant innovations or inventions.

The charge against patented bridge designs was led by the Iowa State Highway Commission, whose head at the time was Thomas MacDonald. MacDonald later became the Director of the Bureau of Public Roads (BPR). As Highway Commissioner and later as BPR Director, MacDonald emphasized scientific bridge designs based on structural mechanics, which met the approval of state and federal officials over private, and often empirically based designs like those of Luten. In Iowa, and many other mid-western states, state engineers often furnished localities with free design work, provided that the local governments excluded bids from private designers. Despite the free help, privately designed bridges often proved to be less expensive to construct than bridges designed according to state plans. Frustrated by the success of empirical designs over their scientific methods, MacDonald and his peers in other states required state approval of bridge designs whenever possible. Luten designs were thought to be particularly weak due to their minimum use of steel and despite their proven resistance to floods and five-year guarantee. MacDonald and others preferred to use the excessive double row of reinforcement of the Thacher system, which by then was public domain.

As more roads came under the purview of federally supported state highway departments, Luten and other entrepreneurial design engineers were forced to compete for an ever-decreasing number of local contracts not subject to state and federal standards. Luten’s companies managed to survive, particularly in the South, until the Depression, when even local road and bridge construction became the domain of the state and federal government. Luten closed his design office in 1932 and purchased a broom factory, the management of which served as his retirement

activity until he died in 1946 (Cooper, 1997). Although no exact numbers are known, as many as thirty thousand bridges may have been constructed with Luten designs. Nearly every state in the Continental United States and many Canadian provinces and Mexican states had Luten bridges.

As Director of the BPR, MacDonald continued his push for scientific designs. He favored designs based on trusses, slabs, and beams, which were easily analyzed and required less empirical formulas than arches. MacDonald also considered reinforced concrete arches to be very susceptible to damage from thermal effects (Cooper, 1997). These opinions were spread down through the ranks to state highway officials, who began to rely less on the arch and more on cheaper, faster ways to construct bridges, such as precast, prestressed concrete beams and steel plate girders. As the costs of these materials declined and the cost of labor increased, the labor-intensive arch form was relegated to bridges built in small culverts, or, in rare cases, for bridges with extremely long spans.

### **Masonry and Concrete Arch Bridges in Virginia**

Bridge technology and construction was minimal in most regions of 17th and 18th century Virginia. Fords served for crossing most streams and rivers, while wet or marshy places were frequently traversed by causeways (raised roads or pathways on a base of stones, logs, timbers, and earth—capped with clay for weatherproofing). Broad rivers were typically crossed by ferries. In the few areas where these methods would not suffice, simple timber bridges were commonly used. These timber bridges took the form of basic beam bridges and the most rudimentary and traditional wooden trusses (e.g., king and queen posts). Stone masonry bridges were expensive and time-consuming to build; only a handful of these structures were erected in Virginia during this period.

The 19th century saw the advent of a number of improved timber truss bridges, including patented varieties, such as the Town lattice truss and the Long panel truss, as well as the combination wood-and-iron Howe truss patented in 1840. A few early 19th-century stone lintel or arched masonry bridges were constructed as well, primarily as turnpike bridges; however, masonry construction generally remained prohibitive in terms of cost and time (Newlon, 1973). Metal truss bridges were first developed in the 1840s and 1850s, although they did not appear in many areas of Virginia until the 1870s. Since most varieties of wooden bridges needed constant maintenance and deteriorated quickly, metal truss bridges were seen as a more long-lasting solution. However, metal truss bridges, besides their greater initial construction costs, still required consistent maintenance, particularly painting, and the cost of upkeep was a constant drain on county budgets. It was a common practice among county governments to delay or ignore what should have been routine maintenance on metal bridges in an effort to stretch dollars, with resultant deterioration and damage to the bridges.

Stone masonry, particularly masonry arch bridges, remained relatively rare in Virginia throughout the 19th century. This was largely due to the cost, time, and skill involved in construction, as well as the need for suitable sources of stone and materials for mortar. Surviving



examples are largely confined to the few turnpike bridges, and, in the last half of the century, in the use of abutments for metal truss bridges and in stone-arched railroad bridges. The oldest surviving masonry arched bridges in Virginia date from the 1820s (with two of these bridges possibly begun in the 1810s); several examples remain.

The masonry arch turnpike bridge over Falling Creek in Chesterfield County was constructed ca. 1823 to serve the Manchester and Petersburg Turnpike. The route subsequently became part of U.S. Rt. 1, and this bridge continued to carry traffic until ca. 1931-1932. When this section of the roadway for this bridge was realigned and straightened, a new bridge was built. The old bridge was taken off system. Two years later, the old structure became the centerpiece of one of the Virginia Department of Highway's first waysides. It remains in that capacity, serving as a wayside footbridge and complemented by a variety of historic markers and a picnic area.

Three intact masonry arch turnpike bridges also survive in Loudoun County. The largest surviving masonry turnpike bridge in Virginia is the 200-foot, four-span Ashby's Gap Turnpike bridge, completed before 1820 and crossing Goose Creek near Atoka (Figure 12). When Rt. 50 was realigned in the mid-20th century, the bridge was taken off system. It is now administered by the Fauquier and Loudoun Garden Club. The other two intact turnpike bridges remain on system. The Little River Turnpike bridge (Loudoun County Structure No. 1025), now carrying Rt. 50 and crossing Little River at Aldie, dates from the period ca. 1810-1824. The Snicker's Gap Turnpike bridge, also known as Hibbs Bridge (Loudoun County Structure No. 6088), completed by 1829, now carries Rt. 734 over Beaverdam Creek.



**Figure 12. The Largest Surviving Masonry Turnpike Bridge in Virginia (The Ashby's Gap Turnpike Bridge crossing Goose Creek near Atoka in Loudoun County, completed before 1820)**

A later stone arch bridge, built ca. 1850 for the Southwest Turnpike Company in Wythe County, is now off-system; however, it still carries trucks accessing a materials storage area. The remains of other masonry turnpike bridges are still in existence in various locations around Virginia.

A number of arched masonry viaducts and culverts on the James River and Kanawha Canal and primarily dating to the 1830s also survive in Virginia. Many of these structures exhibit a high degree of refinement in their craftsmanship. Two of these bridges that remain in-service are the 9th Street bridge in Lynchburg (Lynchburg Structure No. 8044) and the Owens Creek bridge in Nelson County (Nelson County Structure No. 6070). The 9th Street bridge still bears a carved stone plaque with the legend, "Built AD 1839 by J. S. King." The Owens Creek bridge, constructed ca. 1835 as a viaduct, originally carried the canal. Following the canal's acquisition in 1880 by the Richmond and Allegheny Railway Company (which subsequently merged with the Chesapeake and Ohio Railroad), railroad track was laid on the old towpath. The canal bed was filled in, and parts of it now serve as a roadway carrying vehicular traffic. The Owens Creek structure exhibits particularly fine stonework.

Numerous fine examples of the stonemason's art can be seen in surviving railroad bridges from the last half of the 19th century. A small masonry bridge near Gordonsville in Orange County, built in the mid-1850s to carry the Orange and Alexandria Railroad, no longer carries trains. It now serves as a private farm bridge. Also in Orange County is the so-called "Fat Nancy" culvert, a large brick-lined stone culvert constructed just west of the town of Orange in 1888 to serve the Charlottesville and Rapidan Railroad (subsequently the Southern Railway). A typical design used by the Norfolk and Western Railroad, as well as associated railroads such as the [Shenandoah] Valley Railroad, can be seen in the circular masonry arches that are still in evidence in southern, western, and southwestern Virginia. A particularly sizable group of these is the series of brick-lined masonry culverts and underpasses in the vicinity of Honaker in Russell County, most built ca. 1887-1889, with a few later constructions dating to ca. 1913. These structures represent a typical Norfolk and Western Railroad design; like most other structures that were designed and built by this railroad, these bridges were finely executed. Similar stone arches were also built by various other railroad companies in the eastern United States. Of slightly different design is the impressive masonry Roman arch underpass, built in 1896 for the Norfolk and Western Railroad, which continues to support a plate-girder railroad trestle. It also serves as a highway underpass for vehicular traffic on Rt. 645 in Smyth County.

The earliest reinforced concrete bridges in Virginia date from the first years of the 20th century. During the first quarter of this century, the most commonly used reinforced concrete bridges in Virginia were (1) the arch, and (2) girder, or non-arched, construction. The earliest examples of concrete bridge elements identified in the course of this survey both date from 1901. A late 19th century Norfolk and Western Railroad masonry arch bridge, expanded and covered with concrete, dated 1901, still carries trains and serves as an underpass for Rt. 740 at the outskirts of Abingdon in Washington County. A railroad plate-girder bridge, with concrete abutments, also dated 1901, is located over University Avenue in Charlottesville in Albemarle County. A similar set of concrete abutments, dated 1903, supports a plate-girder bridge over Rt.

218 in Stafford County. Just south of this structure is an arched Richmond, Fredericksburg and Potomac Railroad overpass, built in 1904. This structure still carries trains in addition to acting as an underpass for Rt. 630 (Spero, 1984). It is apparently the oldest documented arched bridge in Virginia built completely from reinforced concrete. The second oldest reinforced concrete arch bridge documented in Virginia is also the oldest surviving large-scale arch bridge of its type: a massive bridge carrying North Bridge Street in the city of Bedford. Built in 1906, apparently from standard Norfolk and Western Railroad plans, this bridge has closed spandrel walls in which the concrete is scored with shadow lines to suggest stonework. The solid parapets are molded to suggest post-and-rail construction. The form of such bridges foreshadowed a common type of railroad bridge in Virginia during the early 20th century, similar in form to the older masonry arch bridges, but rendered in reinforced concrete.

For comparison, Virginia's oldest documented non-arched concrete bridge is the 1908 slab bridge, which carries Bedford Avenue in the city of Lynchburg (Structure No. 1849).

In Virginia, as in the nation as a whole, use of reinforced concrete technology grew steadily through the first three decades of the 20th century and become the dominant bridge type. Reinforced concrete bridges were a logical choice. They were perceived and described in early publications as "permanent bridges" that would require little or no maintenance, in contrast to the continual care needed by wooden and metal truss bridges.

William M. Thornton, Dean of Engineering at the University of Virginia and a member of the State Highway Commission, and C. D. Snead, Virginia's State Bridge Engineer, championed the virtues of concrete bridges in the August, 1915 *Bulletin of the Virginia State Highway Commission*, a publication completely devoted to and subtitled, *Highway Bridges and Culverts*. Thornton and Snead recommended concrete bridges for many applications. They cited beam bridges (of timber, steel, or concrete) as the logical application for spans of eight to forty feet. However, in a comparison of material durability, they stated that timber lasts ten years or less, steel lasts twenty-five years, and concrete lasts at least forty years (Thornton and Snead, 1915). Comparing the different types of bridges, they came down solidly on the side of reinforced concrete, noting that:

. . . timber beam bridges must be discarded except for locations where lumber is abnormally cheap and traffic abnormally light. Steel beam bridges of short span with their perishable timber floors are recommended only where the erection gangs are too ignorant to handle reinforced concrete in the right way. Reinforced concrete must be accepted as the economic solution to the problem of the short span highway bridge with spans up to twenty feet. For strength, for durability, for true economy these bridges excel all others . . .

For spans from twenty to forty feet, the steel beam regains its old pre-eminence and is cheaper than the reinforced concrete slab at present normal prices. Bridges consisting of two doubly reinforced concrete girders carrying a reinforced concrete slab floor may be built as cheaply as steel beam bridges for

these spans. The fact that they require more highly skilled labour and direction for their successful erection makes them of doubtful expediency in ordinary highway work. Their low maintenance cost gives them the preference for locations where first-class reinforced concrete can be counted on.

However, they stated their ultimate preference for the arch bridge (Thornton and Snead, 1915) :

In locations where good natural abutments are available the possibilities of erecting a masonry or reinforced concrete arch to carry the bridge should always be considered. Such arched bridges have peculiar aesthetic value. They not only equal all other bridge types in strength, in solidity, in durability, in low cost of maintenance; but they so far excel them in beauty that comparison ceases to be significant. Correctly designed, built with ample waterways and on stable foundations they will stand forever unless the violence of earthquake or crime sweeps them away. This makes them in reality the cheapest of all bridge structures. Where nature provides the foundations nothing equals the arched bridge.

Despite the approval of individuals such as Thornton, arch bridges remained a specialized type of bridge, which were constructed in comparatively small numbers compared to truss, beam, and slab designs. Although notable examples of arched bridges continued to be constructed in Virginia during the first half of the 20th century, the drive towards simplification and standardization spearheaded by men such as Thomas McDonald and the complicated engineering requirements of arch bridges worked against their widespread use.

### **Railings**

The majority of Virginia's surviving 19th century masonry highway bridges have solid masonry parapets, although a few were built with low masonry curbs that apparently supported separate railings, which were probably made of wood or metal. Similarly, most of the Commonwealth's early 20th century concrete arch bridges had either low concrete curbs (with or without the solid, simple parapet railings typical of the era). As was typical for other concrete bridges in the 1920s, the use of solid parapets gave way to vertical and "cork" railings (Miller, McGeehan and Clark, 1996).

Ornate, classical-style, pre-cast balusters were used from the early 20th century onwards. They were typically placed on decorative urban or park bridges. John J. Early used such balusters on a number of projects in the Washington, D.C. area in the 1910s. Contemporary catalogs for Luten's bridge company show similar railings on what he termed "park bridges," as opposed to more utilitarian highway bridges with solid parapets. Examples of these Luten "park bridges" in Virginia are the Main St. and Worsham St. bridges in the city of Danville (Danville

City Structures No. 1811 and No. 8006), built in 1927 and 1928, and Bland Co. Structure No. 1021, built in 1929.

Other concrete arch bridges, particularly those built in urban areas during the first four decades of the 20th century, have decorative molded railings. Notable among these are such structures as the 1913 Mayo Bridge in Richmond (Richmond City Structure No. 1849), which has solid cast panels with a molded lattice decorative motif. The 1906 bridge in the city of Bedford (Bedford City Structure No. 1800), and the three large bridges in the city of Roanoke (Roanoke City Structures Nos. 1815, 1826, and 8003), built in 1926-1927, have concrete parapets molded to suggest square balusters topped with a balustrade.

Decoratively molded concrete streetlight posts, often in the shape of columns or obelisks, were common features of the above urban concrete arch bridges during the first four decades of the 20th century.

Railings or parapets are usually absent from masonry and concrete arch railroad bridges.

### **The Evolution of Standard Plans and Notes on Construction Methodology**

The earliest methods of bridge planning and construction in Virginia involved design and construction of bridges by local contractors. This method held true for the construction of simple timber bridges, timber trusses, and stone masonry bridges. It is probable that each contractor worked with a few time-tested designs that were adapted to the peculiarities of specific sites. With the widespread use of metal truss bridges in the later 19th century and the subsequent advent of concrete bridges, however, came the advent of companies that specifically designed and produced bridges. Such bridge companies frequently worked from standard plans and advertised bridges in different lengths and configurations to suit most sites, tastes, and price ranges. In some cases, bridge companies would also arrange for the erection of the bridges; in other cases, especially involving smaller truss bridges, construction was done by local firms who purchased plans, franchises, and/or structural elements from manufacturers. However, final standards were left to the discretion of either the company, the builder, or the governing body of the county or town in which the bridge was located.

Towards the end of the first decade of the 20th century, there came a radical and permanent change to bridge design in Virginia—that of state-mandated standards. State monetary assistance for counties desiring help with transportation costs, i.e., "state aid," had been established several years earlier on a voluntary basis. The Virginia State Highway Commission, established in 1906, provided both design assistance and some funding to the counties. While transportation systems were still under the control of the counties, any county desiring assistance could apply to the commissioner for engineering advice on proposed road improvements. If the projects were permanent, located on main roads, and were deemed to be "adequate and practical," the commissioner's office would:

. . . carefully prepare plans, specifications and estimates of cost for its construction with the materials agreed upon between the local road authorities and the commissioner . . . If the local road authorities shall then decide to improve or construct said road or part thereof in accordance with the plans and specifications recommended and submitted by the commissioner, they may then apply to the State Highway Commissioner for such State aid . . . as may be obtained under the provisions of this chapter . . .

*(Acts of Assembly, 1908)*

However, the state of many bridges was soon recognized to be not only unreliable, but also unsafe, and in some cases the bridges were in critical condition. Therefore, mandatory bridge standards were required. The 1909 *Annual Report* of the State Highway Commission noted that

. . . the provision in our State aid law permitting any county whose share in the fund does not exceed \$2,500.00 to apply the same to the erection of bridges, has led to a steady increase in work of this character.

Old wooden structures and steel bridges imperfectly designed are frequently found on the most heavily traveled highways, and are often in dangerous condition. This department desiring to meet these conditions, has striven to lend assistance not only to counties where we are giving State aid on permanent bridges, but to all counties asking for such assistance.

After a careful study of the needs and desiring that bridges should be designed and erected according to some specifications which could be used and lived up to as standard by the State and county, this department, last July, issued "General Specifications for Steel Highway Bridges."

. . . Wherever practical reinforced concrete spans have been used. This type of construction requires no maintenance, and its strength increases instead of diminishing with age. Spans from five to fifty feet in length have been designed and constructed. In cases where reinforced concrete cannot be used economically, steel is being employed. Steel bridges from fifteen to five hundred and eighty feet in length have been or are being erected according to the plans of this department and under its supervision.

*(Fourth Annual Report of the State Highway Commissioner, 1909)*

When Virginia, like the rest of the nation, moved into ever greater transportation design standardization, and as the use of automobiles increased, bridges took on lighter, more streamlined outlines. Double lanes became common. Sturdy metal truss or concrete bridges replaced old fords or wooden bridges in many locations. Better means of calculating the amount of reinforcing bar and concrete needed to carry loads safely were being developed in the 1910s and early 1920s.

Although there were numerous state standard plans for non-arched concrete bridges, steel beam bridges, and truss bridges, few standard plans for concrete arch bridges appeared among the state standard plans. The only existing state standard plans for arches date from the mid-1920s and concern large through arches, such as the ones erected along Rt. 1 at that time. The primary standard plans applicable to arch bridges in Virginia were standard plans from the various offices of the Luten Bridge Company.

The new use of reinforced concrete for bridges also required new practices for construction. The "General Note" seen on bridge plans had its roots in the earliest standard plans furnished by the Virginia State Highway Commission. From the beginning, these plans included requirements for construction methods and materials to ensure that at least minimum standards would be followed. Specifications for concrete, steel, masonry, and reinforcing bars were given in these plans. Carrying capacities of bridges also increased. Up to 1920, standard plans specified a capacity of a "twelve-ton road roller" or "twelve tons on two axles." Post-1920 plans specified the capacity to support a fifteen-ton truck, which was quickly superseded by two fifteen-ton trucks passing on the bridge; the capacity was further increased in 1944 to accommodate larger trucks that were being built at that time.

The early specifications included environmental and navigational protections as well. In the construction of early reinforced concrete bridges, extensive wooden forms were made from heavy timbers and boards. Massive falsework was needed to support the plastic and green concrete until it set up and could support its own dead load. There are reminders of this technology in the impressions of the wood grain, including knots from the shuttering boards, which still can be seen on some bridges. Careless disposal of the forms and falsework material constituted environmental hazards, since it could significantly obstruct the waterway channel as well as produce waterborne debris.

## **SURVEY RESULTS AND EVALUATIONS FOR HISTORIC SIGNIFICANCE**

Field survey and related historic research for this project was undertaken in 1996-1998. VDOT records list 127 arch bridges and culverts under Departmental purview, ranging in date from pre-1830 to the later 20th century (APPENDIX C). All of these bridges were included in the survey. As noted previously, the field survey results and the data gathered via documentary historic research were used to produce the historic context for arch bridges in Virginia. Information obtained from the historic context was a major component in determining whether or not a bridge was historically significant.

All masonry and concrete arch bridges under VDOT ownership were evaluated for historic significance by the Historic Structures Task Group during 1997-1999. The evaluation utilized the rating sheet and criteria previously formulated by the Historic Structures Task Group for use in determining the potential historic significance of bridges (APPENDIX D). This rating sheet was adapted from the similar rating sheet developed by DHR for rating buildings and similar structures. This adaptation, which was specifically designed to allow for a more accurate

rating of bridges, was developed in concert with, as well as approved by, DHR. Each bridge was evaluated in terms of a score rating. The maximum possible score with a determination of national significance is 38; the maximum score with a determination of statewide significance is 33; with regional significance, 30; and with local significance, 28. A score of 18 or higher was required for National Register eligibility.

As shown by the eligibility rating sheet, there are eight categories, all rated on numerical scores:

*Level of Significance* indicates whether the structure is of local, regional, statewide, or national significance (5, 7, 10, and 15 points, respectively). Like any other cultural resource subject, most National Register-eligible structures are of local or regional significance, with few that are significant on the state or national level. In the absence of other information, location on a secondary road that had no major historical associations resulted in a rating of local significance; location on a primary road or on a secondary road that had important historical associations resulted in a rating of regional significance. A rating of significance on the state or national level required a major historical or technological association.

*Visual Prominence as a Landmark, Rarity of Bridge Type, Rarity of Design Elements, and Technological Significance (Early Example)* are self-explanatory, and were judged on a scale of from 0 to 3.

*Integrity of Bridge (Condition, Degree of Modification)* was judged on a scale of 1 to 4 (there was no “0” rating in this category, since a bridge with no structural integrity would be unable to stand). The rating considered both structural integrity and the amount of alteration (or lack thereof) from the bridge’s original structure and appearance.

*Contextual Integrity* had two subcategories, both judged on a scale of 0 to 2. *General Surroundings* considered to what degree the area around the bridge (approximately ½ to 1-mile radius) retained its appearance and use at the time that the bridge was constructed. *Immediate and Associated Transportation Resources* considered the presence or absence of any related transportation resources, such as the remains of earlier bridge or railroad lines dating from or before the construction of the current bridge.

The final category, *Historic Significance and Associative Value (including builder)*, was judged on a scale of 0 to 4. This rating considered known factors concerning the history of the bridge, such as association with a turnpike or railroad, whether the builder or designer was known (and if so, whether the builder or designer was significant in the history of bridge construction).

A total of 21 bridges were recommended as eligible for the National Register. A number of these bridges had previously been declared eligible for the Register, and a few had been entered on the Register. In 1998, the final list of arch bridges recommended as eligible for the



National Register was presented to DHR, which gave final concurrence with the Task Group's findings in early 1999. This list, including those bridges already on the National Register, is given below and includes the district and county codes, the structure number (where applicable), type and date of construction, route and crossing, builder or designer, and rating.

### **Bristol District (1)**

#### **Bland County (10)**

No. 1021: Spandrel braced arch with decorative elements (Figure 13), built 1929, Rt. 98 crossing Crab Orchard Creek; Lutten Bridge Co.; decorative elements (fluted street lamp columns, railings) by Pettyjohn Art Concrete Co.; built as a WWI memorial. *Rating: 22.*



**Figure 13. One of Lutten's Spandrel Braced Arches, with Decorative Concrete Elements and "Park Rail," Built in 1929 (Bland County Structure No. 1021)**

#### **Wythe County (98)**

Off Rt. 11: Stone arch, built 1850, crossing Reed Creek; this bridge was built to serve the Southwest Turnpike Company (the predecessor of Rt. 11 in this region). This bridge currently is used by VDOT for access to materials storage. *Rating: 20.*

## Salem District (2)

### City of Bedford (141)

No. 1800: Closed spandrel concrete arch, with decorative elements, including a molded solid parapet and molded horizontal shadow lines on the spandrels to suggest coursed masonry work, built 1906, Rt. 43 crossing Norfolk Southern R.R. *Rating: 18.*

### City of Roanoke (128)

No. 1815: Open spandrel concrete rib arch with ramp and decorative elements, including a molded solid parapet, 1927, Rt. 116 crossing 3rd St. and Norfolk Southern R.R. This bridge, and the following two bridges, are impressive urban bridges with interesting Art Deco design motifs. *Rating: 18.*

No. 1826: Open spandrel concrete rib arch with decorative elements (Figure 14), including a molded solid parapet, 1926, Rt. 11 crossing Roanoke River and Norfolk Southern R.R. *Rating: 19.*

No. 8003: Closed spandrel concrete arch with decorative elements, including a molded solid parapet, 1926, Jefferson St. crossing Norfolk Southern R.R. *Rating: 18.*



**Figure 14. Open Spandrel Rib Arch with Art Deco Design Motifs, Built in 1926  
(City of Roanoke Structure No. 1826)**

### Lynchburg District (3)

#### City of Danville (108)

No. 1811: Open spandrel concrete arch with decorative molded balusters on railing, 1927, Rt. 29/Main St. crossing Dan River, Luten Bridge Co. *Not rated; previously determined eligible as part of a project.*

No. 8006: Open spandrel concrete arch with decorative molded balusters on railing (Figure 15) 1928, Worsham St. crossing Dan River, Luten Bridge Co. *Rating: 20.*



**Figure 15. Open Spandrel Concrete Arch, a Luten Bridge Company Design Built in 1928  
(City of Danville Structure No. 8006)**

#### City of Lynchburg (118)

No. 8006: Solid masonry arch, 1839, 9th St. crossing old James River and Kanawha Canal. This bridge is one of the best-preserved elements of the James River and Kanawha Canal system in Lynchburg. Set into the bridge wall above the arch is a stone inscribed “Built AD 1839 by J. S. King.” *Rating: 22. Note: this bridge was previously entered on the National Register as part of a thematic nomination of James River and Kanawha Canal sites in Lynchburg. The James River and Kanawha Canal system was also previously designated a Virginia Engineering Landmark by the American Society of Civil Engineers.*



## **Nelson County (62)**

No. 6070: Solid masonry arch, ca. 1835, Rt. 606 crossing Owens Creek (Figure 16). This bridge was originally built as a viaduct for the James River and Kanawha Canal. In 1880 the canal was acquired by the Richmond and Allegheny Railway (which later merged with the Chesapeake and Ohio Railway). The railroad track now occupies a portion of the old towpath. The filled bed of the canal is now occupied by Rt. 606. This structure features exceptionally fine masonry work. *Rating: 23. Note: The James River and Kanawha Canal system was also previously designated a Virginia Engineering Landmark by the American Society of Civil Engineers.*

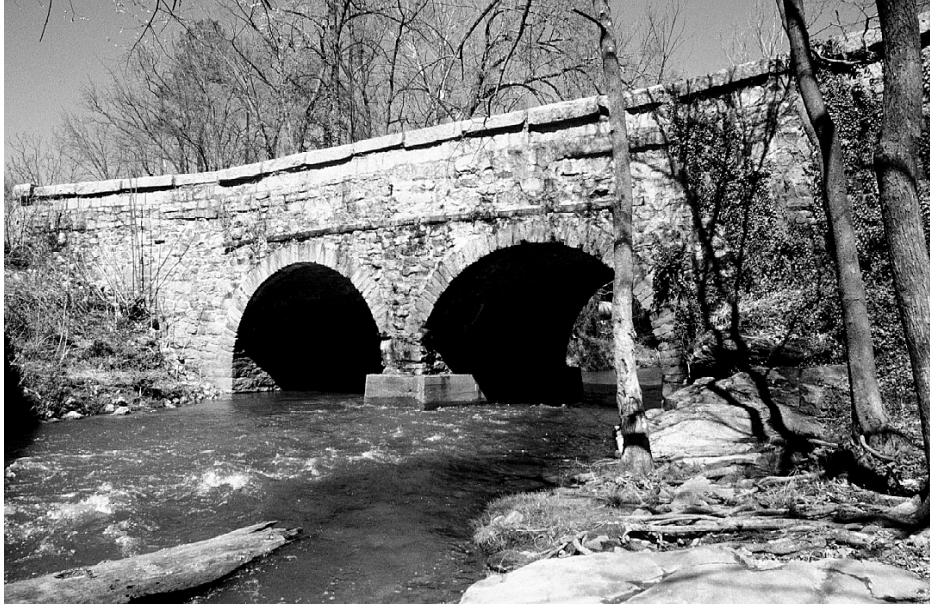

**Figure 16. Solid Masonry Arch, Originally Built ca. 1835 as a Viaduct for the James River and Kanawha Canal (Nelson County Structure No. 6070)**

## **Richmond District (District 4)**

### **Chesterfield County (20)**

Bridge at Falling Creek Wayside, off Rt. 1, crossing Falling Creek, built ca. 1823 by the Manchester and Petersburg Turnpike Co. (Figure 17). The bridge was closed to vehicular traffic in the early 1930s. One of first waysides in Virginia was designed around the old structure, which still serves as a footbridge and landscape feature at Falling Creek Wayside. *Not rated: previously entered on the National Register.*



**Figure 17. Solid Masonry Arch, Built ca. 1823 by the Manchester and Petersburg Turnpike Company (Closed to vehicular traffic in the early 1930s; now serving as a footbridge for the Falling Creek Wayside, Chesterfield County)**

### **Dinwiddie County (26)**

No. 1005: Concrete through arch, 1926, Rt. 1 crossing Stony Creek (Figure 18). This concrete through arch, a design also known as a Marsh arch or rainbow arch, is the only structure of this type remaining in Virginia. *Rating: 22.*

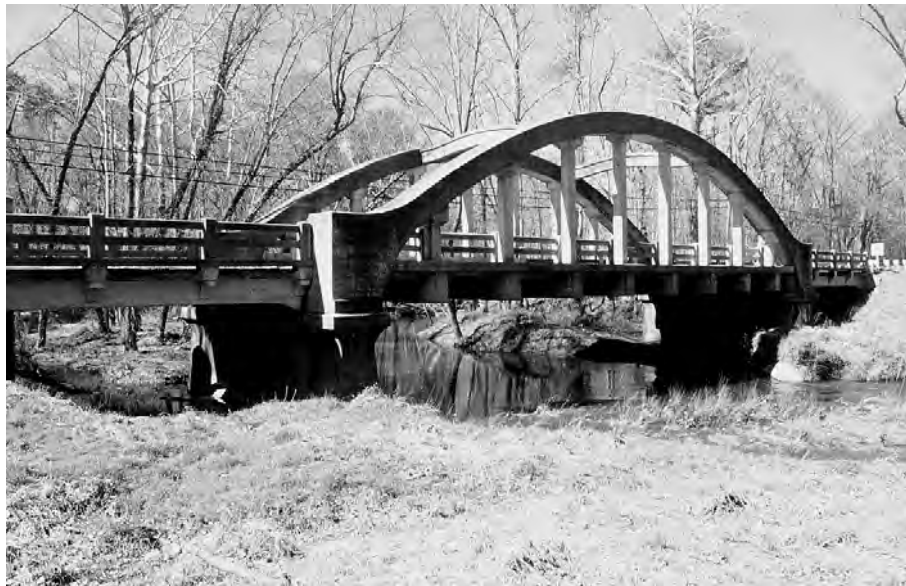

**Figure 18. Concrete Through Arch, Built 1926 (Dinwiddie County Structure No. 1005)**



### **City of Petersburg (123)**

No. 8018: Concrete rigid frame, with brick veneer, Halifax Road and CSX Railroad crossing Defense Road, 1936 (Figure 19). This structure, designed by the U.S. Department of Public Roads, was built as a National Park Service (NPS) project and part of a program of improved access to the Petersburg National Military Park. The use of red brick veneer in the design, which includes brick quoins as well as decorative brickwork representing voussoirs around the arch opening, is typical of one of the mid-20th century NPS design standards calculated to give the structure a period appearance. Other examples of NPS design standards in Virginia can be seen in the bridges along the Colonial Parkway (red brick veneer over concrete) and the Blue Ridge Parkway (stone veneer over concrete). These latter projects were also begun in the 1930s. *Rating: 20.*



**Figure 19. Concrete Rigid Frame with Brick Veneer, a U.S. Department of Public Roads Design, Built in 1936 at the Petersburg National Military Park (City of Petersburg Structure No. 8018)**

### **City of Richmond (127)**

No. 1849: Concrete closed spandrel arch, Rt. 360 crossing James River, 1911-1913 (Figure 20). Designer: Concrete Steel Engineering Company, New York; builder: I. J. Smith and Co., Richmond. Decorative elements include a solid parapet with an intricate cast lattice motif and cast concrete obelisk lampposts. This is the latest of a series of bridges that have spanned the James at this site since the original structure was erected by John Mayo in 1788. The name of “Mayo Bridge” has been attached to subsequent bridges at this crossing. *Rating: 18.*

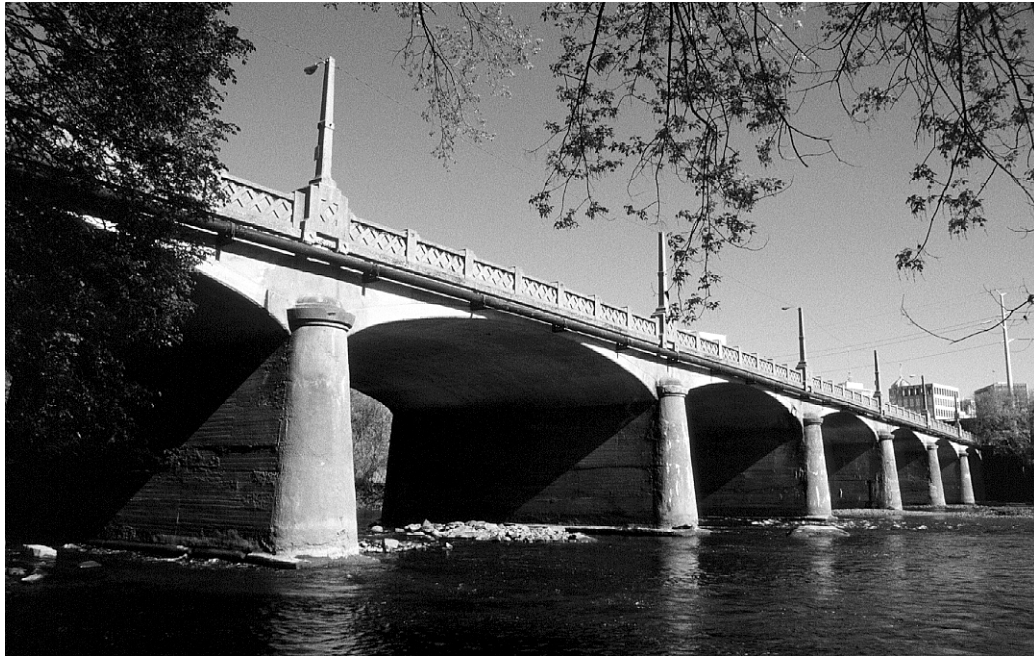

**Figure 20. Concrete Closed Spandrel Arch with Decorative Concrete Elements;  
Designed by the Concrete Steel Engineering Company, New York City, and Built 1911-1913 (City of  
Richmond Structure No. 1949)**

**Suffolk District (District 5)**

**Fredericksburg District (District 6)**

**Culpeper District (District 7)**

No arch bridges within Suffolk, Fredericksburg, or Culpeper districts were determined individually eligible for the National Register.

**Staunton District (District 8)**

**Alleghany Co. (3)**

No. 1923: Open spandrel concrete arch, Rt. 60 crossing Jackson River. *Not rated; previously determined eligible as part of a project; recently replaced with a new bridge.*

**Augusta County (7)**

No. 6165: Spandrel braced arch, 1932, Rt. 835 crossing Jennings Branch; Luten Bridge Co. This is an excellent example of one of Luten's patented designs. *Rating: 18.*



Valley Railroad Bridge, 1874, crossing Folly Mills Creek just west of I- 81, south of Staunton (Figure 21). Originally built to carry rail traffic, the railroad line is abandoned and the bridge is now preserved as a landscape element adjacent to I-81. *Not rated; previously listed on the National Register.*



**Figure 21. Solid Masonry Arch, Built in 1874 for the Valley Railroad (Now a well-known landmark within the right-of-way for I-81)**

### **Frederick County (39)**

No. 6903: Concrete closed spandrel arch bridge, 1917, Rt. 672 crossing Opequon Creek. A metal truss bridge was proposed for this site in 1915. After the patent on the Thacher bar reinforcing system was overturned in 1916, this concrete bridge was quickly designed and built instead, utilizing the Thacher system. *Rating: 19.*

### **Rockbridge County (81)**

No. 1012: Rigid frame with stone veneer, 1940, Rt. 39 crossing Laurel Run (Figure 22). This bridge was designed as part of the improvements to Rt. 39 running through Goshen Pass. This design was part of the Virginia Department of Highway's landscaping for this project, which was carefully planned to complement the scenic Goshen Pass. This project was the Department's first large-scale integration of highway design and landscaping in order to avoid or minimize highway impact to a historic/scenic area. *Rating: 20.*





**Figure 22. Rigid Frame with Stone Veneer, Built in 1940 as Part of the Improvements to Rt. 39 in Goshen Pass (Rockbridge County Structure No. 1012)**

### **Northern Virginia District (District A)**

#### **Loudoun County (53)**

No. 1025: Masonry arch bridge, ca. 1810-1824, Rt. 50 crossing Little River. Built by the Little River Turnpike Company. *Rating: 23. Note: this bridge was previously determined to be a contributing element within the Aldie Mill Historic District.*

No. 6088: Masonry arch bridge, ca. 1829, Rt. 734 crossing Beaverdam Creek. Built by the Snickersville Turnpike Company. *Rating: 18.*

Also:

*Ashby's Gap Turnpike Bridge. Note: no longer under VDOT's purview, but especially notable, is the Ashby's Gap Turnpike bridge, constructed before 1820 and crossing Goose Creek near Atoka in Loudoun County. Taken off system when Rt. 50 was realigned in the 1950s, the bridge is now administered by the Fauquier and Loudoun Garden Club, a member club of the Garden Club of Virginia. It was listed on the National Register in the 1970s and is the largest surviving masonry turnpike bridge in Virginia.*

### **SUMMARY AND CONCLUSIONS**

This project produced a comprehensive survey, historic context, and evaluation for all masonry and concrete arch bridges under VDOT's purview. Out of a total of 127 bridges, 21 bridges were recommended as individually eligible for the National Register. This number included a number of bridges that had previously been declared eligible for the Register, and a few that had been entered on the Register before. In 1998, the final list of arch bridges recommended as eligible for the National Register was presented to DHR, which gave final concurrence with the Task Group's findings in early 1999.

The National Register-eligible arch bridges can be added to the other National Register-eligible bridges already identified by previous surveys and incorporated into the ongoing historic bridge management system.

This study eliminated the need for costly and time-consuming individual bridge studies that can unnecessarily slow construction and rehabilitation projects. Aside from identifying Virginia's historically significant arch bridges, the study also identified 106 non-significant bridges that can now undergo necessary maintenance and upgrade as needed without further extensive study.

## **RECOMMENDATIONS**

1. A listing of Virginia's 21 National Register-eligible arch bridges, as well as the 106 non-eligible arch bridges, should be appended to the existing Memorandum of Agreement (MOA) between VDOT and the Department of Historic Resources.
2. The arch bridge historic survey information should be updated at least every 15 to 20 years. This update should consist of noting any bridges that have been demolished or taken out of service and should document any changes to the structures.

## **ACKNOWLEDGMENTS**

The authors wish to express their gratitude to the many VTRC, VDOT, and FHWA employees who made possible this publication. Several groups and individuals deserve particular mention:

The input of the multidisciplinary State Historic Structures Task Group was extremely useful. Members of the VDOT Environmental Division in general, both in the Central Office and the construction districts, provided helpful suggestions for this report. District Bridge engineering personnel provided valuable information on the early arch bridges in their districts. The VDOT Structure and Bridge Division at Central Office, particularly Thomas F. Lester, John E. Coleman, and Gregory A. Freed, as well as Claude S. Napier, Jr. of FHWA, answered our numerous inquiries, helped us locate elusive archival material and provided us with encouragement and suggestions.

At VTRC, Thomas L. Samuel, Jr. and M. Damon Weiss, Research Assistants, worked with us in the field survey of the bridges, and analysis and presentation of field data. Michael A. Perfater, a VTRC Manager, and Gary R. Allen, Director, provided administrative and technical direction. Howard H. Newlon, Jr., former Director of the Research Council, shared with us his extensive knowledge of the history of bridge construction.

## REFERENCES

- Acts and Joint Resolutions Passed by the General Assembly of the State of Virginia.* 1908. Richmond, Superintendent of Public Documents.
- Cooper, James L. 1997. *Artistry and Ingenuity in Artificial Stone, Indiana's Concrete Bridges, 1900–1942.* Greencastle, IN: Depauw University.
- Fourth Annual Report of the State Highway Commissioner* 1909. Richmond: Superintendent of Public Documents.
- Hopkins, H.J. 1970. *A Span of Bridges, an Illustrated History.* New York: Praeger Publishers, Inc.
- McCullough, Conde B. and Edward S. Thayer. 1948. *Elastic Arch Bridges.* New York: John Wiley & Sons, Inc.
- Miller, Ann B., Daniel D. McGeehan and Kenneth M. Clark. 1996. *A Survey of Non-Arched Historic Concrete Bridges in Virginia Constructed Prior to 1950.* Charlottesville: Virginia Transportation Research Council.
- Miller, Ann B., and Kenneth M. Clark. 1997. *A Survey of Metal Truss Bridges in Virginia.* Charlottesville: Virginia Transportation Research Council.
- Miller, Ann B., and Kenneth M. Clark. 1998. *A Survey of Movable Span Bridges in Virginia.* Charlottesville: Virginia Transportation Research Council.
- Newlon, Howard, Jr. November, 1973. *Backsights: Build Us a Bridge.* Virginia Department of Highways and Transportation Bulletin.
- Spero, Paula A. C. 1984. *Criteria for Preservation and Adaptive Use of Historic Highway Structures, Final Report.* Charlottesville: Virginia Highway & Transportation Research Council. (Note: This publication is a survey and photographic inventory of concrete and masonry arch bridges in Virginia.)
- Thornton, William M., and C. D. Snead. (1915. *Bulletin of the Virginia State Highway Commission, 1915.* Richmond: Davis Bottom, Superintendent of Public Documents.
- Whitney, Charles S. (1929. *Bridges.* New York: William Edwin Rudge.

**APPENDIX A**  
**ARCH BRIDGE SURVEY FORM**

**INVENTORY FORM – Transportation Related Historic Resources**

Photo

Numbers:

Geographic Information

Object: \_\_\_\_\_.

State: Virginia

Va. Department of Transportation District: \_\_\_\_\_; No. \_\_\_\_\_.

County: \_\_\_\_\_; No. \_\_\_\_\_.

City/Town: \_\_\_\_\_; Vicinity: \_\_\_\_\_; No. \_\_\_\_\_.

Near Street/Road: \_\_\_\_\_.

Locator: \_\_\_\_\_.

UTM/KGS Coordinates: \_\_\_\_\_.

Historic Information

Formal designation: \_\_\_\_\_.

Local designation: \_\_\_\_\_.

Designer: \_\_\_\_\_.

Builder: \_\_\_\_\_.

Date: \_\_\_\_\_; basis for: \_\_\_\_\_.

Original Owner: \_\_\_\_\_; use: \_\_\_\_\_.

Present Owner: \_\_\_\_\_; use: \_\_\_\_\_.

Cultural Resources

Contextual Integrity:

General surroundings: \_\_\_\_\_.

\_\_\_\_\_.

Immediate surroundings: \_\_\_\_\_.

\_\_\_\_\_.

Associated resources: \_\_\_\_\_.

\_\_\_\_\_.

Nature/Degree of any destructive threat: \_\_\_\_\_.

\_\_\_\_\_.

\_\_\_\_\_.

Reference materials and contemporary photos/illustrations with their respective locations:

Recorder: \_\_\_\_\_.

Date: \_\_\_\_\_.

Affiliation: \_\_\_\_\_.

Design Information

Compass orientation of axis: \_\_\_\_\_.

Dimensions: length \_\_\_\_\_; width \_\_\_\_\_; height \_\_\_\_\_.

Architectural or decorative features:

Structural Information

Material(s): \_\_\_\_\_.

Other:

Sketch

Side Elevation

Section A-A

## APPENDIX B

### DANIEL B. LUTEN AND THE LUTEN BRIDGE COMPANY

Due in part to the large number of his bridges that were constructed, Daniel B. Luten is a significant name in the annals of early 20th century American arch bridge designers. Literally tens of thousands of Luten-designed bridges were constructed between ca. 1900 and 1932. These bridges are readily identifiable by their characteristic designs and identifying plates (Figure 23).

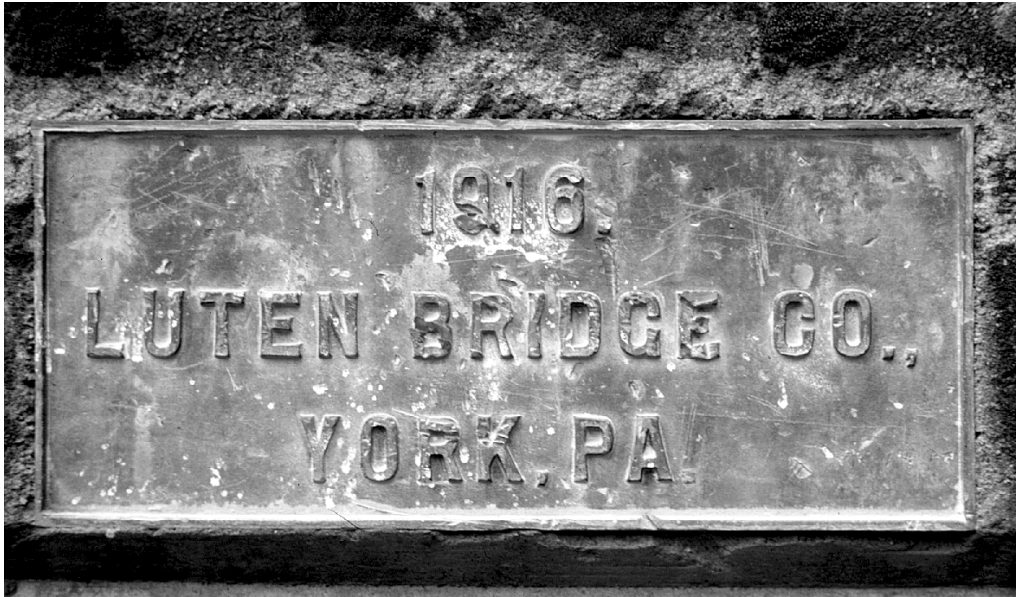

Figure 23. Typical Plaque of the Luten Bridge Company of York, Pennsylvania and of Knoxville, Tennessee

Some state historic preservation offices consider any Luten bridge to be historically significant (possibly in large part because these early bridges can be so easily identified). However, the Historic Preservation Task Group takes a more conservative view for Virginia, weighing age and technology more heavily than a large number of existing bridges and identification of the builder. As this report indicates, a number of Virginia's Luten bridges are eligible for the National Register; however, these are bridges that exhibit other technological factors in addition to merely being Luten bridges.

Given the large number of surviving Luten bridges in Virginia, and since relatively little information is readily available on Luten, an overview of Luten and his career is included here to provide an additional context for Luten bridges.



Daniel B. Luten was born on a farm near Grand Rapids, Michigan in 1869. He worked his way through the University of Michigan, graduating with a degree in civil engineering in 1894. He studied elastic arch theory under Professor Green for another year and then went on to teach sanitary and architectural engineering at Purdue (Cooper 1997). While at Purdue, Luten developed and patented his first reinforced concrete bridge design. At the time, there were essentially two schools of engineering thought. One, in the French tradition, emphasized rigorous theoretical and mathematical methods to solve engineering problems. While accurate, this method was very time-consuming, especially in an age without electronic computing devices. For this reason, American and British engineers of the late nineteenth and early twentieth centuries favored a more empirical approach, with information such as material and design strength established by testing.

In developing his design philosophy, Luten incorporated both theoretical and empirical traditions. Using his firm understanding of elastic theory, Luten developed a system of empirical shortcuts that shortened the solution of elastic arch problems from days to hours. When subjected to tests on models, Luten's formulas proved accurate to within ten percent of results obtained by elaborate, precise elastic analysis. The economy of time realized by his analytical shortcuts proved to be very important as Luten began his career as a design and consulting engineer (Cooper 1997).

Luten left Purdue in 1900, armed with his design philosophy and first patent, which had been granted that year. It was his firm belief that the best application of his engineering skills was neither in academia nor the public sector, where material rewards for innovative thinking and design economy were few. In his writings for contemporary engineering media, Luten emphasized economy almost as much as strength, and encouraged engineers to reap the rewards of the patent system (Cooper 1997). By 1927, Luten had received nearly fifty patents for designs and devices related to reinforced concrete construction, with nearly one-third of these being actual bridge designs. Reduction of costs, without reduction of strength, was the motivation for his designs.

The reduction of steel and concrete were the principal means by which Luten reduced the cost of his bridges. Elastic theory had taught him that the use of reinforcing steel only needed to be included in areas of tension. While this concept is well understood now, in Luten's day the Thacher method of reinforcing was strongly favored, and his peers considered him bold and often foolish for not including what was actually an excess of reinforcing steel. Luten went on to further reduce the amount of material in his bridges by uniting the entire structure, including arch ring, spandrel walls, piers and abutments with steel bars and ties. In such a configuration, all the elements of the bridge helped to carry load, thereby reducing the amount any one element must bear. This allowed elements to be designed for lower forces and consequently less material was used. Other Luten patents sought to reduce the labor and time costs of construction with special re-bar clamps, formwork, and centering.

Luten's first patent was for a modest arch that incorporated steel or wooden ties connecting the abutments. Located beneath the streambed, these ties resisted the lateral thrust of the arch ring and enabled the bridge to be built with a very flat arch and exceedingly light abutments. Subsequent patents protected his ideas of structural integration, which, in the more advanced stages, approached the design of arched rigid frames. One innovative patent, called a double drum arch, reduced the amount of concrete used in the arch ring by splitting it into two layers with compacted earth between. This provided adequate strength where it was most needed, at the outer edges of the arch ring, while allowing cheaper material to be used in the center where stresses are low. Luten's most efficient design, the spandrel braced arch, used thirty percent less steel and forty percent less concrete than contemporary bridges with similar capacity (Cooper 1997). Developed in the early twenties, the spandrel braced arch integrated the arch ribs, spandrels, and deck slab into a structure capable of carrying heavy loads at high speeds without interrupting the hard road surface. By contrast, many bridges of the day used either timber decks or gravel fill for surfacing and bore signs warning travelers to travel slowly when crossing.



**Figure 24. An Early 20th Century Advertisement for Luten Engineering Depicting the Wabash River Bridge in Georgetown, Indiana**

After receiving a patent for the tied arch in 1900, Luten set out to sell his design by mail with a catalog. Initially business was slow, and during the early years he acted as design engineer, concrete laborer, and framing carpenter. Using money borrowed from his wife and sister-in-law, Luten formed the National Bridge Company in 1901. The seventeen bridges he built that year netted a profit of only a thousand dollars, with no salary for Luten. Undaunted, in 1902 he moved from Lafayette, Indiana to Indianapolis and incorporated the National Bridge Company. For his initial and all subsequent patents, Luten received half of the twenty-four thousand dollars of capital stock and became president. Other family members purchased the remaining stock and served as board of directors (Cooper 1997).

One of Luten's first actions as president was to retain the services of a Chicago patent lawyer, who was soon inundated with new bridge designs and concrete devices, including a prefabricated re-bar cage for slabs that was marketed as the Luten Truss. The years of 1902 to 1905 were difficult ones for Daniel Luten. Although a flood of railway related contracts in 1903 helped ameliorate the losses of previous years, it was difficult to juggle invention, design, and construction contracts at once. In 1905 Luten helped organize the National Concrete Company, a concrete construction firm which would take over the construction side of the National Bridge Company's work and leave Luten free to concentrate on developing new designs and protecting his existing patents in court. The National Bridge Company held ten percent of the National Concrete Company's stock and received royalties on contracts using Luten designs, which the concrete company agreed to promote. Months after incorporation, the National Concrete Co. received a contract for a 700-foot span over the Wabash River in Peru, Indiana. As Luten's first large structure, it proved his innovative talents, but it was not until 1911 that he had the opportunity to work on another large bridge (Cooper 1997).

Nevertheless, the corporate partnership proved to be a successful one, a success that was radically bolstered when the flood of 1913 swept away more than one hundred bridges in Indiana. Only two of Luten's twenty-two bridges were damaged, and his three large bridges survived intact. The flood not only provided Luten and his associates with business, but an opportunity to highlight the superiority of his permanent, flood-proof bridges over the metal trusses which were easily swept away by the high water. The year 1913 was a good year for the National Bridge Company; its dozen engineers and draftsmen handled over two million dollars worth of contracts that year (Cooper 1997).

Throughout his career, Luten continued to market his bridges through his catalog and other advertisements (Figure 24), as well as offering to license anyone to build one of his patented designs for a royalty. To supplement these passive marketing strategies, the National Bridge Company used a network of agents to secure design contracts outside of Indiana. These contracts were handled in one of two ways: either the National Bridge Company would furnish bridge contractors with the drawings and a license for ten percent of the contract bid, or they would send an agent with the drawings and reinforcing steel to act as the foreman and supervisor for a local crew of workers. Soon six other construction companies in five states had relationships with the National Bridge Company similar to that of the National Concrete Company (Cooper 1997).

While some of Luten's agents simply marketed his bridges for a commission, many others were also involved in the construction of Luten Bridges. Some of these agents formed companies using Luten's name in their title, as was the case of the Luten Bridge Company of York, Pa. This company was incorporated in 1909 with capital stock of \$5,000. By 1914 this had increased to \$75,000, with numerous branch offices established throughout the eastern states. Most of the Luten Bridges in Virginia were built by this company's York, Pa., or Clarksburg, W.Va. offices. The other builder of Luten bridges in Virginia was the Luten Bridge Co. of Knoxville, Tenn., which was incorporated by some of the sons of the founders of the York firm (Cooper 1997).

Luten's success could never have been realized without the patent system. The protection offered by patents made it profitable for Luten to devise a series of reinforced concrete designs and devices, which effected a dramatic savings of material and cost. This reduced construction cost more than offset the royalty fee for the license. Consequently, the annulment of Luten's patents in the late teens and early twenties dealt a serious blow to his companies. No longer could Luten inundate the market with catalogs and advertisements of his designs, because anyone could use them free of charge. Instead, he used his network of agents and companies to quietly market his designs, including his most efficient, the spandrel braced arch. The low cost and longevity (the spandrel braced arches are among the strongest existing Luten bridges in Virginia) of this design made it a popular choice for county governments with few resources to commit to the expensive long-term maintenance necessary for steel bridges. Luten's designs and marketing strategy ideally suited local governments charged with improving their rural roads on limited budgets. However, this market shrank rapidly throughout the twenties as more county roads were absorbed into state systems subject to federal design standards. The Depression all but eliminated the rural bridge market, as most localities could no longer fund infrastructure improvements. The rise and fall of the private bridge designer was summarized by one of Luten's associates as a man ascending a ladder. Upon reaching the top the man "must back down or jump off. We all just jumped off, that's all." Luten replied: "Somebody jerked the ladder out from under me" (Cooper, 1997).

**APPENDIX C**

**INVENTORY OF VIRGINIA'S ARCH BRIDGES UNDER VDOT'S PURVIEW**



# *Inventory of Arched Bridges under VDOT Purview.*

<i>Bridge ID:</i>	<i>District</i>	<i>Route:</i>	<i>Crossing:</i>	<i>Year:</i>	<i>Length (ft) (m)</i>	<i>Individually Eligible:</i>	<i>Arch Type:</i>
Alleghany 6012	Staunton	Rt. 616	Karnes Creek	1932	10 3	No	culvert <sup>1</sup>
Alleghany 1923	Staunton	Rt. 60	Jackson River	1923	326 101	Yes	open spandrel rib
Alleghany 1900	Staunton	Rt. 60	Jackson River	1929	394 122	No	open spandrel rib
Alleghany 6142	Staunton	Rt. 633	Trib. Cowpasture River		18 6	No	culvert <sup>1</sup>
Alleghany 6143	Staunton	Rt. 633	Trib. Cowpasture River		14 4	No	culvert <sup>1</sup>
Amherst 1028	Lynchburg	Rt. 130	Cashaw Creek	1928	22 7	No	closed spandrel filled
Arlington 1038	NOVA	Rt. 27	Rt. 244	1945/ 1973 <sup>2</sup>	67 21	No	rigid frame
Augusta 1102	Staunton	Rt. 11	Christians Creek	1950	55 17	No	culvert <sup>1</sup>
Augusta, Valley RR Arch	Staunton	Adj. I-81	Folly Mills Creek	1874		Yes	masonry voussoir
Augusta 6165	Staunton	Rt. 835	Jennings Branch	1932	60 19	Yes	spandrel braced
Augusta 1100	Staunton	Rt. 11	Trib. Christians Creek	1950	18 6	No	culvert <sup>1</sup>
Augusta 6212	Staunton	Rt. 747	Cattle Pass	1925	13 4	No	culvert <sup>1</sup>
Augusta 6211	Staunton	Rt. 747	Stream	1920	15 5	No	culvert <sup>1</sup>

<b>Bridge ID:</b>	<b>District</b>	<b>Route:</b>	<b>Crossing:</b>	<b>Year:</b>	<b>Length (ft) (m)</b>	<b>Individually Eligible:</b>	<b>Arch Type:</b>
Augusta 1046	Staunton	Rt. 254	Middle River	1926	103	No	open spandrel rib
Bath 1010	Staunton	Rt. 39	Stuart Run	1928	84	No	closed spandrel filled
Bath 6137	Staunton	Rt. 687	Warm Springs Run	1932	27	No	masonry voussoir
Bath 1034	Staunton	Rt. 39	Trib. Jackson River	1932	29	No	masonry voussoir
Bedford City 1800	Salem	Rt. 43	N. S. RR	1906	159	Yes	closed spandrel filled
Bland 1021	Bristol	Rt. 98	Crab Orchard Creek	1929	43	Yes	spandrel braced
Brunswick 1001	Richmond	Rt. 1	Wagua Creek	1926/ 1981 <sup>2</sup>	151	No	open spandrel rib
Buckingham 1024	Lynchburg	Rt. 60	Austin's Run	1931	20	No	culvert <sup>1</sup>
Campbell 6027	Lynchburg	Rt. 624	Timberlake Spillway		26	No	rigid frame
Campbell 6039	Lynchburg	Rt. 643	Falling River	1928	239	No	open spandrel rib
Campbell 6098	Lynchburg	Rt. 704	Seneca Creek	1928	96	No	open spandrel rib
Campbell 6099	Lynchburg	Rt. 704	Seneca Creek	1928	86	No	open spandrel rib
Charlottesville 8013	Culpeper	Rugby Rd	CSX RR	1921	16	No	closed spandrel filled
Chesterfield, Falling Creek Arch	Richmond	off Rt. 1	Falling Creek	1823	134	Yes	masonry voussoir
Cumberland 6059	Lynchburg	Rt. 690	Punch Creek		8	No	culvert <sup>1</sup>



<i><b>Bridge ID:</b></i>	<i><b>District</b></i>	<i><b>Route:</b></i>	<i><b>Crossing:</b></i>	<i><b>Year:</b></i>	<i><b>Length (ft) (m)</b></i>	<i><b>Individually Eligible:</b></i>	<i><b>Arch Type:</b></i>
Danville 8006	Lynchburg	Worsham St.	Dan River	1928	1151 357	Yes	open spandrel rib
Danville 1811	Lynchburg	Rt. 29 / Main St.	Dan River	1927	829 257	Yes	open spandrel rib
Dinwiddie 1005	Richmond	Rt. 1	Stony Creek	1926	167 52	Yes	open spandrel through
Fairfax 1056	NOVA	Rt. 244	Holmes Run	1961	69 21	No	closed spandrel filled
Fairfax 6008	NOVA	Rt. 617	RF&P RR (abandoned)	1946	16 5	No	masonry voussoir
Fairfax 1093	NOVA	Rt. 193	Bullneck Creek	1893	8 2	No	masonry voussoir
Fauquier 6013	Culpeper	Rt. 605	Cedar Run	1919	34 11	No	closed spandrel filled, masonry veneer
Fauquier 6033	Culpeper	Rt. 624	Goose Creek	1919	67 21	No	closed spandrel filled
Fauquier 6034	Culpeper	Rt. 624	Branch of Goose Creek	1919	23 7	No	closed spandrel filled
Fauquier 6233	Culpeper	Rt. 628	Branch of Barton Creek	1930	18 6	No	masonry culvert <sup>1</sup>
Fluvanna 1010	Culpeper	Rt. 250	Mechunk Creek	1933	180 56	No	open spandrel rib
Franklin 6109	Salem	Rt. 724	Chestnut Creek	1932	66 20	No	closed spandrel filled
Frederick 6016	Staunton	Rt. 608	Gap Run	1929	28 9	No	closed spandrel filled
Frederick 6903	Staunton	Rt. 672	Opequon Creek	1917	209 65	Yes	closed spandrel filled
Frederick 1010	Staunton	Rt. 55	Duck Run	1941	117 36	No	open spandrel rib

<b>Bridge ID:</b>	<b>District</b>	<b>Route:</b>	<b>Crossing:</b>	<b>Year:</b>	<b>Length (ft) (m)</b>	<b>Individually Eligible:</b>	<b>Arch Type:</b>
Giles 6080	Salem	Rt. 648	Adair Run	1951	41 13	No	closed spandrel filled
Grayson 1023	Bristol	Rt. 89	Blue Ridge Parkway	1949	129 40	No	rigid frame, masonry veneer
Halifax 6154	Lynchburg	Rt. 663	Birch Creek	c. 1928	20 6	No	closed spandrel filled, masonry veneer
Halifax 6061	Lynchburg	Rt. 663	Birch Creek	c. 1928	22 7	Not Rated	closed spandrel filled, masonry veneer
Hanover 1003	Richmond	Rt. 1	South Anna River	1925	279 86	No	closed spandrel filled
Henry 1014	Salem	Rt. 58	Smith River	1927	419 130	No	open spandrel rib
Lee 6401	Bristol	Rt. 740	N. Fork Powell River	1918	43 13	No	closed spandrel filled
Loudoun 1025	NOVA	Rt. 50	Little River	c. 1820	58 18	Yes	masonry voussoir
Loudoun 6346	NOVA	Rt. 751	Trib. of NF of Catoctin Creek	1932	16 5	No	masonry culvert
Loudoun 6088	NOVA	Rt. 734	Beaverdam Creek	c. 1829	69 21	Yes	masonry voussoir
Loudoun 6146	NOVA	Rt. 690	Trib of Catoctin Creek	1916	12 4	No	culvert <sup>1</sup>
Loudoun 6090	NOVA	Rt. 734	N. Fork Beaverdam Creek	1915	45 14	No	closed spandrel filled
Loudoun 6079	NOVA	Rt. 725	Crooked Run	c. 1917	52 16	No	closed spandrel filled
Loudoun 6048	NOVA	Rt. 674	Trib. of Dutchman's Creek	1916	29 9	No	closed spandrel filled
Loudoun 6045	NOVA	Rt. 661	Trib. of Limestone Branch	1917	49 15	No	closed spandrel filled

<b>Bridge ID:</b>	<b>District</b>	<b>Route:</b>	<b>Crossing:</b>	<b>Year:</b>	<b>Length (ft) (m)</b>	<b>Individually Eligible:</b>	<b>Arch Type:</b>
Loudoun 6031	NOVA	Rt. 626	Beaverdam Creek	1925	50 16	No	closed spandrel filled
Loudoun 6019	NOVA	Rt. 719	Panther Skin Creek	1916	21 7	No	closed spandrel filled
Loudoun 1018	NOVA	Rt. 7	Quail Creek		6 2	No	culvert <sup>1</sup>
Loudoun 1003	NOVA	Rt. 699 (old Rt. 7)	Abandoned W&OD RR	1900	26 8	No	masonry voussoir
Lynchburg 1829	Lynchburg	Park Ave.	N.S. RR	1932	30 9	No	closed spandrel filled
Lynchburg 8039	Lynchburg	D - Street	ravine	1909 / 1981 <sup>2</sup>	320 99	No	closed spandrel filled
Lynchburg 1845	Lynchburg	Rt. 221	College Creek / Lake	1935	98 30	No	closed spandrel filled
Lynchburg 8044	Lynchburg	9th Street	James River & Kanawha Canal	1839	1151 357	Yes	masonry voussoir
Montgomery 6030	Salem	Rt. 617	Brush Creek	1929	33 10	No	culvert <sup>1</sup> , 3 span
Nelson 6070	Lynchburg	Rt. 606	Owens Creek	1835	37 11	Yes	masonry voussoir
Page 6003	Staunton	Rt. 624	Trib. Hawksbill Creek	1930	4 1	No	culvert <sup>1</sup>
Petersburg 8018	Richmond	Halifax Rd. & CSX RR	Defense Rd.	1936	36 11	Yes	rigid frame, brick veneer
Pulaski 6020	Salem	Rt. 627	Neck Creek	1927	108 33	No	open spandrel rib
Pulaski 6001	Salem	Rt. 600	Back Creek	1930	122 38	No	open spandrel rib
Pulaski 6186	Salem	Rt. 693 at Rt. 672	Trib. New River	1923	22 7	No	culvert <sup>1</sup>

<i>Bridge ID:</i>	<i>District</i>	<i>Route:</i>	<i>Crossing:</i>	<i>Year:</i>	<i>Length (ft) (m)</i>	<i>Individually Eligible:</i>	<i>Arch Type:</i>
Pulaski 6012	Salem	Rt. 789	Thornsprings Branch	1932	42 13	No	spandrel braced
Pulaski 6005	Salem	Rt. 693	Mack Creek	1929	62 19	No	spandrel braced
Richmond City 1849	Richmond	Rt. 360	James River	1913	841 261	Yes	closed spandrel filled
Roanoke City 8003	Salem	Jefferson St.	N. S. RR	1926	380 118	Yes	closed spandrel filled
Roanoke City 1815	Salem	Rt. 116	3rd St. / N. S. RR	1927	887 275	Yes	open spandrel rib
Roanoke City 1826	Salem	Rt. 11	Roanoke River / N. S. RR	1926	640 198	Yes	open spandrel rib
Rockbridge 1012	Staunton	Rt. 39	Laurel Run	1940	31 10	Yes	rigid frame, masonry vener
Rockbridge 6326	Staunton	Rt. 676	Sugar Creek	1932	19 6	No	culvert <sup>1</sup>
Rockbridge 6166	Staunton	Rt. 611	stream	1932	24 7	No	closed spandrel filled
Rockbridge 1116	Staunton	Rt. 251	Colliers Creek	1926 / 1955 <sup>2</sup>	24 7	No	closed spandrel filled
Rockbridge 6504	Staunton	Rt. 612	Bull Run Creek	1932	11 3	No	culvert <sup>1</sup>
Rockbridge 6322	Staunton	Rt. 672	Walters Creek	1932	8 2	No	culvert <sup>1</sup>
Rockingham 1134	Staunton	Rt. 259	Trib Shenandoah River	1942	25 8	No	closed spandrel filled
Rockingham 6055	Staunton	Rt. 752	Trib. Tide Spring Branch	1925	8 2	No	culvert <sup>1</sup>
Rockingham 6398	Staunton	Rt. 747	Cattle Pass / Stream	1925	8 2	No	culvert <sup>1</sup>

<b>Bridge ID:</b>	<b>District</b>	<b>Route:</b>	<b>Crossing:</b>	<b>Year:</b>	<b>Length (ft) (m)</b>	<b>Individually Eligible:</b>	<b>Arch Type:</b>
Rockingham 1131	Staunton	Rt. 259	N. Fork Shenandoah River	1943	18 6	No	culvert <sup>1</sup>
Rockingham 1129	Staunton	Rt. 259	Wet Weather Stream	1943	12 4	No	culvert <sup>1</sup>
Rocky Mount 1900	Salem	Rt. 220	Pigg River	1928	174 54	No	open spandrel rib
Scott 6069	Bristol	Rt. 650	Stock Creek	1922	120 37	No	open spandrel rib
Scott 6089	Bristol	Rt. 665	Copper Creek	1928	150 47	No	spandrel braced arch
Scott 6474	Bristol	Rt. 796	Big Moccasin Creek	1932	160 50	No	closed spandrel filled
Shenandoah 6060	Staunton	Rt. 1419	Stony Creek	1921	91 28	No	low water bridge <sup>3</sup>
Shenandoah 6047	Staunton	Rt. 675	Stony River	1932	98 30	No	low water bridge <sup>3</sup>
Shenandoah 6049	Staunton	Rt. 760	Stony River	1932	101 31	No	low water bridge <sup>3</sup>
Shenandoah 6386	Staunton	Rt. 675	Stony Creek	1932	100 31	No	low water bridge <sup>3</sup>
Shenandoah 6044	Staunton	Rt. 667	N. Fork Shenandoah River	1932	99 31	No	low water bridge <sup>3</sup>
Smyth 6088	Bristol	Rt. 689	Mid. Fork Holston River	1928	57 18	No	closed spandrel rib
Tazewell 1054	Bristol	Rt. 91	Poor Valley Creek	1924	113 35	No	closed spandrel filled

<i>Bridge ID:</i>	<i>District</i>	<i>Route:</i>	<i>Crossing:</i>	<i>Year:</i>	<i>Length (ft) (m)</i>	<i>Individually Eligible:</i>	<i>Arch Type:</i>
Tazewell 6233	Bristol	Rt. 770	Indian Creek	1932	53 16	No	closed spandrel filled
Tazewell 6269	Bristol	Rt. 637	Clinch River	1923	178 55	No	open spandrel rib
Tazewell 6059	Bristol	Rt. 637	Dry Fork Creek	1923	106 33	No	closed spandrel filled
Tazewell City 1802	Bristol	Rt. 16 Alt	Clinch River	1923	98 30	No	closed spandrel filled
Washington 6244	Bristol	Rt. 689	branch	1927	13 4	No	culvert <sup>1</sup>
Washington 6243	Bristol	Rt. 689	branch	1927	16 5	No	culvert <sup>1</sup>
Washington 6283	Bristol	Rt. 726	stream	1937	20 6	No	culvert <sup>1</sup>
Washington 6242	Bristol	Rt. 689	branch	1927	12 4	No	culvert <sup>1</sup>
Washington 6432	Bristol	Rt. 726	stream	25 8	No	closed spandrel filled	
Wise 6097	Bristol	Rt. 1308	Callahan Creek	1926	82 25	No	open spandrel rib
Wise 1042	Bristol	Rt. 835	Pound River	1930	177 55	No	open spandrel rib
Wise 6062	Bristol	Rt. 657	Bull Run Creek	1924	52 16	No	closed spandrel rib
Wise 6095	Bristol	Rt. 1321	Powell River	1928	140 43	No	open spandrel rib
Wise 1009	Bristol	Rt. 78	Callihan Branch	1926	96 30	No	open spandrel rib
Wise 6063	Bristol	Rt. 657	Bull Run Creek	1932	53 16	No	closed spandrel rib

<b>Bridge ID:</b>	<b>District</b>	<b>Route:</b>	<b>Crossing:</b>	<b>Year:</b>	<b>Length (ft) (m)</b>	<b>Individually Eligible:</b>	<b>Arch Type:</b>
Wythe, SW Turnpike Arch	Bristol	Adj. Rt. 11	Trib. of Reed Creek	c. 1850	36 11	Yes	masonry voussoir
Wythe 6046	Bristol	Rt. 671	Cripple Creek	1930	47 15	No	spandrel braced

1. Structures listed as “culvert” are of the closed-spandrel filled arch type.
2. Two dates indicate the original construction date and the date of major reconstruction.
3. Structures listed as “low water bridge” generally consist of multiple small, low, closed spandrel filled arches.

James City 1021	Suffolk	Rt. 199	Colonial Parkway	1976		Not Rated	closed spandrel filled
James City 1020	Suffolk	Rt. 199	Colonial Parkway	1968		Not Rated	closed spandrel filled
Williamsburg 8002	Suffolk	Newport St.	Colonial Parkway	1952		Not Rated	closed spandrel filled
Williamsburg 1804	Suffolk	Rt. 31 / Rt. 5	Colonial Parkway	1936	56 17	Not Rated	closed spandrel filled
Williamsburg 1811	Suffolk	Rt. 143	Colonial Parkway	1948		Not Rated	closed spandrel filled
Williamsburg 1812	Suffolk	Rt. 162 / Rt. 5 / Rt. 31	Colonial Parkway	1936	118 37	Not Rated	closed spandrel filled
Williamsburg 1815	Suffolk	Rt. 163	Colonial Parkway	1972		Not Rated	closed spandrel filled
York 2005	Suffolk	Rt. 64	Colonial Parkway	1965		Not Rated	closed spandrel filled
York 2006	Suffolk	Rt. 64	Colonial Parkway	1965		Not Rated	closed spandrel filled

*Bridges associated with the Colonial Parkway were not rated for individual eligibility due to their design similarities. The Task Group recommends that these structures be considered contributing elements to the entire Colonial Parkway.*

# Summary of Inventory

## Span Types

<i>Span Type</i>	<i>Total</i>	<i>Bristol</i>	<i>Culpeper</i>	<i>Lynchburg</i>	<i>NOVA</i>	<i>Richmond</i>	<i>Salem</i>	<i>Staunton</i>	<i>Suffolk</i>
closed spandrel filled	45	7	4	6	7	2	4	6	9
closed spandrel rib	3	3							
other	32	4	1	2	3		2	20	
masonry voussoir	12	1		2	5	1		3	
open spandrel rib	23	6	1	5		1	6	4	
open spandrel through	1					1			
rigid frame	5	1		1	1	1		1	
spandrel braced	6	3					2	1	

60

## The "other" category covers small structures such as low water bridges and culverts

		<i>Construction Dates</i>				
<i>Year</i>	<i>Number of Bridges</i>	<i>Year</i>				
		1901 - 1910	1911 - 1920	1921 - 1930	1931 - 1940	1941 - 1950
Before 1830	3	2	13	52	27	10
1831 - 1840	2					2
1841 - 1850	1					6
1851 - 1860	0					6
1861 - 1870	0					6
1871 - 1880	1					6
1881 - 1890	0					6
1891 - 1900	2					6
<b>Total</b>						

127



**APPENDIX D**  
**BRIDGE ELIGIBILITY RATING SHEET**

## BRIDGE ELIGIBILITY RATING SHEET

District: \_\_\_\_\_ County: \_\_\_\_\_

Structure No.: \_\_\_\_\_ Route: \_\_\_\_\_ Crossing: \_\_\_\_\_

### I. Categories

- A. DHR Theme(s):
- B. Period(s) of Significance:
- C. Area(s) of Significance:
- D. National Register Criteria:

### II. Assignment of Basic Points

A.	Level of Significance (local, regional, state, national)	5	7	10	15	
		none	somewhat		yes	very
B.	Visual Prominence as a Landmark	0	1	2		
C.	Rarity of Bridge Type	0	1	2	3	
D.	Rarity of Design Elements	0	1	2	3	
E.	Technological Significance (early example)	0	1	2	3	
F.	Integrity of Bridge (Condition, Degree of Modifications)	0	1	2	3	4
G.	Contextual Integrity					
	(1) General Surroundings	0	1	2		
	(2) Immediate and associated transportation resources	0	1	2		
H.	Historic Significance and Associative Value (including builder)	0	1	2	3	4